

## Refrigerator Service and Maintenance Manual

i.Series® and Horizon Series™ - Pass-Thru

### Pharmacy

#### i.Series

iPR225, iPR456

#### Horizon Series

HPR225, HPR456

### Blood Bank

#### i.Series

iB225, iB456

#### Horizon Series

HB225, HB456



## Document History

Revision	Date	CO	Supersession	Revision Description
A	15 NOV 2016	12321	n/a	Initial release (all units with serial number 2035000 and greater).
B	28 MAR 2017	12701	B supersedes A	Added Appendix A and B to include compliance and warranty information. Updated the Emergo address.
C	12 JAN 2018	13333	C supersedes B	<ul style="list-style-type: none"><li>• Updated hysteresis data.</li><li>• Clarified defrost event default settings in Table 7.</li><li>• Updated schematics to include changes in Temperature Chart Recorder and Defrost Timer.</li><li>• Added FCC compliance information.</li></ul>
D	6 JUN 2019	14712	D supersedes C	Updated text in Sections 2, 4 and 6 to include information regarding the i.Lock Interlock feature.

\* Date submitted for Change Order review. Actual release date may vary.

## Document Updates

The document is furnished for information use only, is subject to change without notice and should not be construed as a commitment by Helmer Scientific. Helmer Scientific assumes no responsibility or liability for any errors or inaccuracies that may appear in the informational content contained in this material. For the purpose of clarity, Helmer Scientific considers only the most recent revision of this document to be valid.

## Notices and Disclaimers

### Confidential / Proprietary Notices

Use of any portion(s) of this document to copy, translate, disassemble or decompile, or create or attempt to create by reverse engineering or otherwise replicate the information from Helmer Scientific products is expressly prohibited.

### Copyright and Trademark

Copyright © 2019 Helmer, Inc. Helmer®, i.Series®, i.C<sup>3</sup>®, Horizon Series™, and Rel.i™ are registered trademarks or trademarks of Helmer, Inc. in the United States of America. All other trademarks and registered trademarks are the property of their respective owners. Helmer, Inc., doing business as (DBA) Helmer Scientific and Helmer.

### Disclaimer

This manual is intended as a guide to provide the operator with necessary instructions on the proper use and maintenance of certain Helmer Scientific products.

Any failure to follow the instructions as described could result in impaired product function, injury to the operator or others, or void applicable product warranties. Helmer Scientific accepts no responsibility for liability resulting from improper use or maintenance of its products.

The screenshots and component images appearing in this guide are provided for illustrative purposes only, and may vary slightly from the actual software screens and/or product components.

# Contents

- 1 About this Manual . . . . . 4**
  - 1.1 Intended Use . . . . . 4
  - 1.2 Safety Symbols and Precautions . . . . . 4
  - 1.3 Model and Input Power . . . . . 6
  - 1.4 Product Labels . . . . . 6
- 2 Installation and Configuration . . . . . 7**
  - 2.1 Location Requirements . . . . . 7
  - 2.2 Placement and Leveling . . . . . 7
  - 2.3 Connect Back-Up Power . . . . . 7
  - 2.4 Prepare for Monitoring . . . . . 8
  - 2.5 Configure Storage . . . . . 10
  - 2.6 Optional Adapter Kits for Medication Dispensing Locks . . . . . 11
- 3 Controls . . . . . 12**
  - 3.1 Home Screen and Screensaver . . . . . 12
  - 3.2 Home Screen Functions . . . . . 12
  - 3.3 Alarm Reference . . . . . 13
  - 3.4 Settings . . . . . 13
  - 3.5 Sensor Calibration . . . . . 17
- 4 Maintenance . . . . . 22**
  - 4.1 Alarm Tests . . . . . 23
  - 4.2 Upgrade System Firmware . . . . . 24
  - 4.3 Test and Replace Back-up Batteries . . . . . 25
  - 4.4 Check Probe Bottle . . . . . 25
  - 4.5 Clean Refrigerator . . . . . 25
- 5 Service . . . . . 27**
  - 5.1 Refrigerant . . . . . 27
  - 5.2 Replace LED Lamp Strip . . . . . 27
  - 5.3 Remove / Replace Unit Cooler Cover . . . . . 27
- 6 Troubleshooting . . . . . 29**
  - 6.1 General Operation Problems . . . . . 29
  - 6.2 Chamber Temperature Problems . . . . . 30
  - 6.3 Alarm Activation Problems . . . . . 30
  - 6.4 Testing Problems . . . . . 31
  - 6.5 Condensation Problems . . . . . 32
- 7 i.Series® Parts . . . . . 33**
- 8 Schematics . . . . . 36**
  - 8.1 iB and iPR Models; 225 and 456 Configurations . . . . . 36
  - 8.2 iB and iPR Models; 225 and 456 Configurations with i.Lock™ Interlock . . . . . 38

**9 Installation and Configuration . . . . . 39**

9.1 Location Requirements . . . . . 39

9.2 Placement and Leveling . . . . . 39

9.3 Connect Back-Up Power. . . . . 40

9.4 Prepare for Monitoring . . . . . 40

9.5 Configure Storage . . . . . 42

9.6 Optional Adapter Kits for Medication Dispensing Locks . . . . . 43

**10 Controls . . . . . 44**

10.1 Monitor and Control Interface . . . . . 44

10.2 Alarm Reference . . . . . 46

10.3 Settings . . . . . 46

**11 Maintenance. . . . . 50**

11.1 Alarm Tests . . . . . 51

11.2 Test and Replace Back-up Batteries . . . . . 52

11.3 Check Probe Bottle . . . . . 52

11.4 Clean the Refrigerator. . . . . 52

**12 Service . . . . . 54**

12.1 Refrigerant . . . . . 54

12.2 Replace LED Lamps . . . . . 54

12.3 Remove / Replace Unit Cooler Cover . . . . . 55

**13 Troubleshooting . . . . . 56**

13.1 General Operation Problems . . . . . 56

13.2 Chamber Temperature Problems . . . . . 56

13.3 Alarm Activation Problems . . . . . 57

13.4 Condensation Problems . . . . . 58

**14 Horizon Series™ Parts . . . . . 59**

**15 Schematics . . . . . 62**

15.1 HB and HPR Models . . . . . 62

15.3 Defrost Timer for HPR Model; 225 and 456 Configuration . . . . . 63

**16 Compliance . . . . . 64**

16.1 Safety Compliance . . . . . 64

16.2 Environmental Compliance . . . . . 64

16.3 EMC Compliance . . . . . 64

**Appendix A: Warranty . . . . . 65**

## 1 About this Manual

This manual provides information on i.Series® and Horizon Series™ pass-thru blood bank and pharmacy refrigerators. It is intended for use by end users of the refrigerator and authorized service technicians.

Models are indicated by a distinguishing model number that corresponds to the series, type, number of doors, and capacity of the refrigerator. For example, “iB225” refers to an i.Series Blood Bank refrigerator with two doors total (one door on the clean room side of the unit, and one door on the control side of the unit) and an approximate capacity of 25 cu ft.

Generic references are used throughout this manual to group models that contain similar features. For example, “225 models” refers to all models of that size (iB225, HB225, iPR225, HPR225). This manual covers all pass-thru refrigerators, which may be identified singly, by their size, or by their respective “Series.”

### 1.1 Intended Use

#### Note

This equipment has been tested and found to comply with the limits for a Class A digital device, pursuant to part 15 of the FCC Rules. These limits are designed to provide reasonable protection against harmful interference when the equipment is operated in a commercial environment. This equipment generates, uses and can radiate radio frequency energy and, if not installed and used in accordance with the instruction manual, may cause harmful interference to radio communications. Operation of this equipment in a residential area is likely to cause harmful interference in which case the user will be required to correct the interference at his own expense.

Helmer refrigerators are intended for the storage of blood products and other medical and scientific products.

### 1.2 Safety Symbols and Precautions

#### *Symbols found in this document*

The following symbols are used in this manual to emphasize certain details for the user:



**Task** Indicates procedures which need to be followed.



**Note** Provides useful information regarding a procedure or operating technique when using Helmer Scientific products

**NOTICE** Advises the user against initiating an action or creating a situation which could result in damage to equipment; person injury is unlikely.

**CAUTION** Advises the user against initiating an action or creating a situation which could result in damage to equipment or impair the quality of the products or cause minor injury.

**WARNING** Advises the user against initiating an action or creating a situation which could result in damage to equipment and serious personal injury to a patient or the user.



Manufacturer



Authorized representative in the European Community

### Symbols found on the unit

The following symbols may be found on the refrigerator or refrigerator packaging:



CE Mark (European units only)



Earth / ground terminal



Caution: Risk of damage to equipment or danger to operator



Protective earth / ground terminal



Caution: Hot surface



Compliance with Restriction of Hazardous Substances Directive



Caution: Shock / electrical hazard



Compliance with European Union Directive WEEE 2002/96/EC applicable provisions.



Caution: Unlock all casters

### Safety Precautions

#### Avoiding Injury

Review safety instructions before installing, using, or maintaining the equipment.

- ◆ Before moving unit, ensure doors are closed and casters are unlocked and free of debris.
- ◆ Before moving unit, disconnect the AC power cord and secure the cord.
- ◆ Do not open multiple, loaded drawers at the same time.
- ◆ Do not move a unit whose load exceeds 900 lbs / 408 kg (225 models) or 1350 lbs / 612 kg (456 models).
- ◆ Never physically restrict any moving component.
- ◆ Avoid removing electrical service panels and access panels unless so instructed.
- ◆ Keep hands away from pinch points when closing the door.
- ◆ Avoid sharp edges when working inside the electrical compartment and refrigeration compartment.
- ◆ Ensure biological materials are stored at recommended temperatures determined by standards, literature, or good laboratory practices.
- ◆ Proceed with caution when adding and removing samples from the refrigerator.
- ◆ Use manufacturer supplied power cord only.
- ◆ Using the equipment in a manner not specified by Helmer Scientific may impair the protection provided by the equipment.
- ◆ Ensure biological materials are stored safely, in accordance with all applicable organizational, regulatory, and legal requirements.
- ◆ The refrigerator is not considered to be a storage cabinet for flammable or hazardous materials.

#### CAUTION

Decontaminate parts prior to sending for service or repair. Contact Helmer or your distributor for decontamination instructions and a Return Authorization Number.

### 1.3 Model and Input Power

**Note**

Service information varies depending on the model and power requirements.

**Table 1. Model and Input Power**

Model	Voltage	Frequency	Current Draw
225	115V	60 Hz	9.25 A
	230V	50 Hz	5.1 A
	230V	60 Hz	5.8 A
456	115V	60 Hz	13.25 A
	230V	50 Hz	7.8 A
	230V	60 Hz	8.2 A

\* Amperage values are subject to change. Refer to the product specification label on your unit for current values.

### 1.4 Product Labels

This information appears on the product specification label, located on the top of the refrigerator next to the electrical box. The model also appears on a label located in the chamber on the upper side of the right wall.

**Note**

Information contained in this specification label varies depending on the model and power requirements.

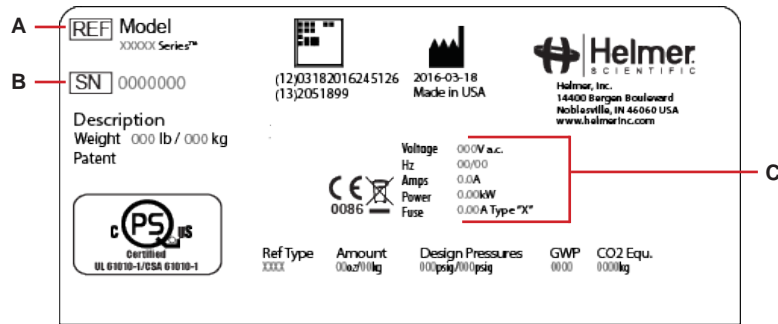

Label	Description
A	Model (REF)
B	Serial number
D	Power requirements

*Sample Product Specification Label*

## i.Series® Information

### 2 Installation and Configuration

#### 2.1 Location Requirements

- ◆ Grounded outlet meeting the electrical requirements listed on the product specification label.
- ◆ Clear of direct sunlight, high temperature sources, and heating and air conditioning vents.
- ◆ Meets limits specified for ambient temperature (15°C to 32°C) and relative humidity.
- ◆ Minimum 8" (203 mm) above.
- ◆ Clearance above the clean room side may be 0".
- ◆ Top enclosure cannot be placed more than 11" (280 mm) from the front (clean room side) of the refrigerator.
- ◆ Side enclosures may be flush with both sides of the refrigerator.

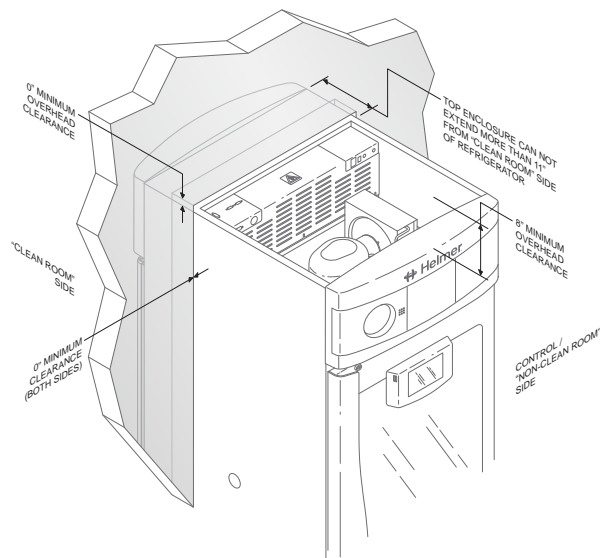

#### 2.2 Placement and Leveling

##### CAUTION

- To prevent tipping, ensure the casters are unlocked and doors are closed before moving the refrigerator.

- ◆ Roll refrigerator into place and lock casters.
- ◆ Ensure refrigerator is level.

#### 2.3 Connect Back-Up Power

The monitoring system and chart recorder each have a back-up battery system, enabling a period of continuous operation if power is lost.

Battery life varies by manufacturer as well as voltage level remaining. Providing full power is available and no battery-related alarms are active, back-up power for the monitoring system is available for up to 20 hours (the Low Battery alarm will activate after approximately 18 hours of battery use). Providing full power is available, back-up power for the optional i.Lock™ interlock feature is available for up to 2 hours.

##### CAUTION

Before installing or replacing batteries, switch AC power and back-up battery OFF. Disconnect refrigerator from AC power.

##### **i** Notes

- The optional i.Lock™ interlock feature (*available only in Pharmacy models*) uses the monitoring system back-up battery for back-up power in the event of power failure.
- The monitoring system will start on back-up battery power alone. If the refrigerator was not previously connected to AC power and the back-up battery is switched on, the monitoring system will begin running on back-up battery power.
- If AC power is lost, the monitoring system will automatically disable some features to prolong back-up battery power. Data collection will continue until back-up battery power is depleted.



The back-up battery is located on top of the refrigerator.

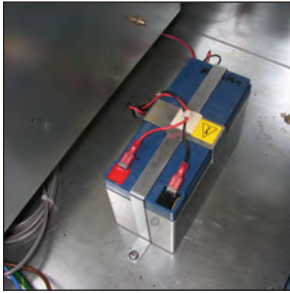

*Monitoring system back-up battery  
(supplies power to optional i.Lock interlock)*

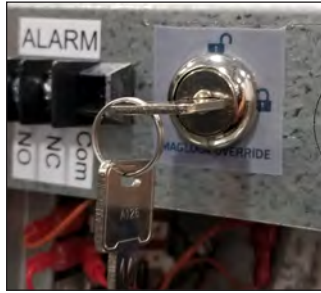

*i.Lock interlock key switch*

## 2.4 Prepare for Monitoring

The back-up battery switch is switched off for shipping. Switch the back-up battery switch ON to provide the monitoring system and optional i.Lock interlock with back-up power in the event of AC power failure.

### Temperature Probes

#### Notes

- Temperature probes are fragile; handle with care.
- The number and location of probes varies by model.
- Remote probes may also be introduced through the existing top ports, and immersed in existing probe bottles.

Probe bottle(s) along with a container of glycerin have been provided with this unit. The glycerin is used to create a solution which simulates the product stored in the refrigerator. The product simulation solution temperature reflects the product's temperature during normal operation.

Each probe bottle should contain 4 oz. (120 mL) of product simulation solution at a 10:1 ratio of water to glycerin.



*Left: Probe bottle with temperature and chart recorder probes.  
Right: Top access port.*

#### Fill Probe Bottle

1. Remove all probes from bottle and remove bottle from bracket.
2. Remove cap and fill with 4 oz. (120 mL) of product simulation solution.
3. Install cap and place bottle in bracket.
4. Replace probes, immersing at least 2" (50 mm) in solution.

#### Install Additional Probe Through Top Port

1. Peel back putty to expose port.
2. Insert probe through port into chamber.
3. Insert probe into bottle.
4. Replace putty, ensuring a tight seal.

**Chart Recorder (if included)****Note**

- If chart recorder has been operating on battery power, the battery should be replaced to ensure the back-up source has proper charge.
- For complete information, refer to the Temperature Chart Recorder Operation and Service Manual included with the unit.

The chart recorder has a back-up battery system, enabling a period of continuous operation if power is lost. Battery life varies by manufacturer as well as voltage level remaining. Providing full power is available, back-up power for the temperature chart recorder is available for up to 14 hours.

**Prior to use:**

Place probe in bottle with primary monitor probe.

**Set up and Operation**

Access chart recorder by pressing and releasing the door to open.



*i.Series chart door*

**Install Battery**

Connect the leads to the battery to provide back-up power to the chart recorder.

**Install / Replace Chart Paper****Note**

- For accurate temperature reading, ensure the current time is aligned with the time line groove when chart knob is tightened.
- Contact Helmer Customer Service to reorder chart paper; part number 220366 (52 sheets)

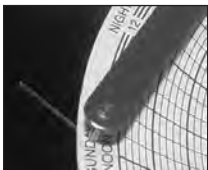

*Chart recorder stylus and time line groove*

1. Press and hold **C** button. When stylus begins to move left, release button. The LED flashes.
2. When stylus stops moving, remove chart knob then move knob up and away.
3. Place chart paper on chart recorder.
4. Gently lift stylus and rotate paper so current time line corresponds to time line groove.
5. Hold chart paper in place while making sure the chart knob is fully tightened. (*Failure to fully tighten the knob can result in paper slipping and losing time.*)
6. Press and hold **C** button. When stylus begins to move right, release button.
7. Confirm stylus is marking on paper and stops at the correct temperature.
8. Calibrate chart recorder to match primary temperature if needed and close recorder door.

## External Monitoring Devices

The remote alarm interface is a relay switch with three terminals:

- ◆ Common (COM)
- ◆ Normally Open (NO)
- ◆ Normally Closed (NC)

Terminals are dry contacts and do not supply voltage. Interface circuit is either normally open or normally closed, depending on terminals used.

Requirements for your alarm system determine which alarm wires must connect to terminals.

### CAUTION

- The interface on the remote alarm monitoring system is intended for connection to the end user's central alarm system(s) that uses normally-open or normally-closed dry contacts.
- If an external power supply exceeding 30 V (RMS) or 60 V (DC) is connected to the remote alarm monitoring system's circuit, the remote alarm will not function properly and may cause damage to the control board or result in injury to the user.

The terminals on the remote alarm interface have the following maximum load capacity:

- ◆ 0.5 A at 30 V (RMS)
- ◆ 1.0 A at 24 V (DC)

### Connect to Remote Alarm Interface

1. On the electrical box, locate the remote alarm terminals.
2. Connect remote alarm wires to appropriate terminals, according to requirements for your alarm system.
3. Use a cable tie to relieve strain on alarm wires (as necessary).

## 2.5 Configure Storage

### CAUTION

- Before moving drawers, ensure they are completely empty for safe lifting.
- Maximum basket, drawer, or shelf load is 100 lbs (46 kg).

### Note

Before moving storage components, protect stored items in refrigerator from extended exposure to adverse temperature.

## Product Loading Guidelines

When loading your refrigerator, take care to observe the following guidelines:

- ◆ Never load refrigerators beyond capacity.
- ◆ Always store items within shelves, drawers or baskets.
- ◆ Temperature uniformity is maintained by air circulation, which could be impeded if unit is overfilled, particularly at the top or against the doors or walls. Ensure proper clearance is provided below the fan.

### Note

Products stacked against walls or doors may obstruct air flow and affect performance of unit.

## Drawers and Baskets

### Remove Drawer or Basket

1. Pull drawer or basket out until it stops.
2. On the right rail, locate the release tab and press downward.
3. While holding the right release tab downward, locate the release tab on the left rail and press upward.
4. Pull drawer or basket free of the slides.

### Install Drawer or Basket

1. Align end guides on drawer or basket with the slides.
2. Gently push drawer or basket into chamber until it stops.
3. Pull drawer or basket out until it stops; check for smooth operation.

 **Move Drawer Slides**

1. Using a screwdriver, remove front bracket retainers.
2. Tap front brackets upward to disengage standards.
3. Remove slides from standards.
4. Insert slides into standard at appropriate height.
5. Tap front brackets downward to engage standards.
6. Using a screwdriver, install front bracket retainers.

**Shelves** **Remove Shelf**

1. With one hand, lift front edge of the shelf from the front brackets.
2. With the other hand, reach under the shelf and bump rear edge of the shelf upward to disengage rear brackets.

 **Install Shelf**

1. Insert shelf into chamber, placing it on brackets.
2. Gently bump rear edge of the shelf downward to engage brackets.
3. Pulling shelf forward gently; shelf should not disengage from rear brackets

 **Move Shelf Brackets**

1. Using a screwdriver, remove front bracket retainers.
2. Tap front brackets upward to disengage standards.
3. Remove front brackets from standards.
4. Insert front brackets into standard at appropriate height.
5. Tap front brackets downward to engage standards.
6. Using a screwdriver, install front bracket retainers.

**2.6 Optional Adapter Kits for Medication Dispensing Locks**

Contact Helmer Technical Service or your distributor for service documentation pertaining to medication dispensing locks.

### 3 Controls

i.Series models are equipped with the i.C<sup>3</sup> monitoring and control system. The i.C<sup>3</sup> system combines temperature control and monitoring into a single user interface.

#### Note

Please refer to the i.C<sup>3</sup> User Guide for complete information regarding the i.C<sup>3</sup> User Interface.

#### 3.1 Home Screen and Screensaver

The Home Screen is the default screen and is displayed when:

- ◆ The Home icon is touched from any other screen.
- ◆ There is no interaction for two minutes on any screen other than those used to enter a password.

The Screensaver is automatically displayed after 2 minutes of inactivity on the Home Screen.



Home Screen

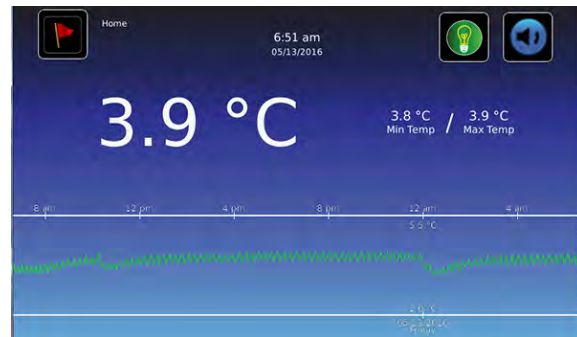

Screensaver

#### 3.2 Home Screen Functions

#### Note

Refer to the i.C<sup>3</sup> User Guide for options available on all i.C<sup>3</sup> screens.

- ◆ View current interior cabinet temperature readings
- ◆ View min/max temperature occurrence for a specified time period
- ◆ View the current system time and date
- ◆ Access any of the five homescreen applications (touch **i.C<sup>3</sup> APPS** for additional applications)
- ◆ View information about current alarm events
- ◆ View whether the monitoring system is running on battery power
- ◆ Mute audible alarms
- ◆ Turn the chamber light on and off
- ◆ View a graph of the chamber temperature
- ◆ View unit ID
- ◆ Shortcut to Event Log

### 3.3 Alarm Reference

If an alarm condition is met, an alarm activates. Some alarms are visual only; others are visual and audible. Some alarms are sent through the remote alarm interface. The table below indicates if an alarm is audible (A), visual (V), or sent through the remote alarm interface (R).

**Table 2. i.Series Alarm Reference**

Alarm	Alarm Type	Alarm	Alarm Type
High Temperature	A, V, R	Low Battery	V
Low Temperature	A, V, R	No Battery	A, V, R
Compressor Temperature	A, V, R	Probe Failure	A, V, R
Door Open (Time)	A, V, R	Communication Failure	A, V, R
Power Failure	A, V, R		

### 3.4 Settings



Through the i.C³ monitoring and control system, current settings may be viewed and changed. To view settings, touch **i.C³ APPS**, **Settings**. Use a touch-drag motion to scroll up or down to select the desired setting.

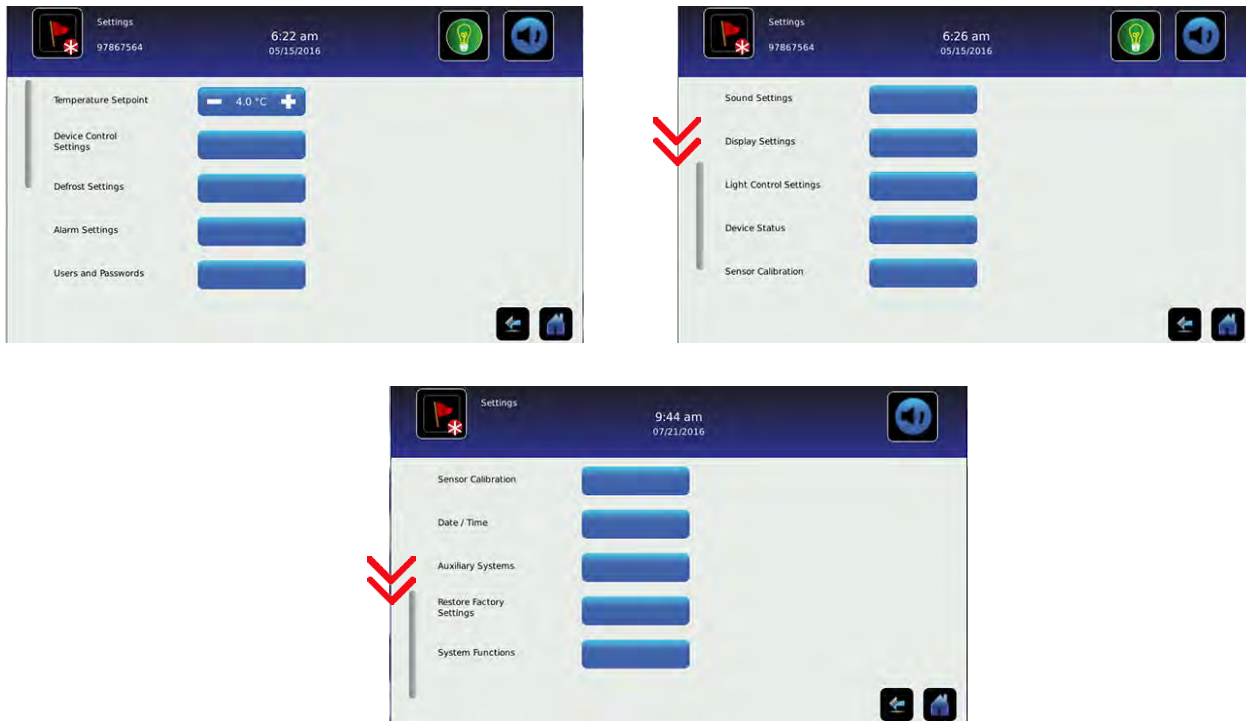

*Settings screens*

**Note**

- If the Settings screen is password protected enter appropriate password. If viewing settings for the first time, enter factory default password of "1234".
- Default values for general settings, alarm settings, and display settings are available in the i.C³ User Guide.
- Changing temperature settings affects operation of the refrigerator. Do not change settings unless instructed in product documentation or by Helmer Technical Service.

The i.C³ temperature monitor and controller is programmed at the factory. To change a setting, first enter the Settings screen, then select the setting. The method for accessing the Settings mode for each setting varies.

## Device Control Settings

Device control settings are programmed at the factory. Setpoints can be viewed and changed through the i.C<sup>3</sup> monitoring and control system. To view temperature setpoints, touch **i.C<sup>3</sup> APPS, Settings, Device Control Settings**.

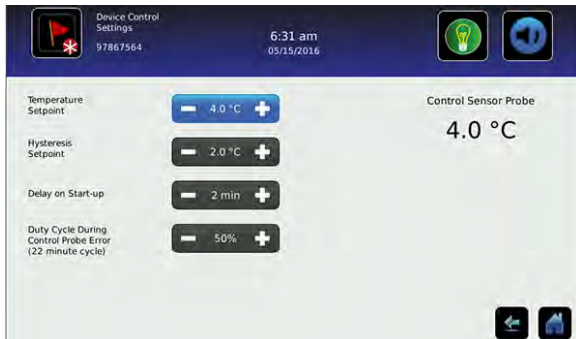

Device Control Settings screen.

Table 3. Setpoints

Setting	Initial Factory Value
Temperature Setpoint	4.0 °C
Hysteresis Setpoint	2.0 °C*
Delay on Start-Up	2 minutes
Duty Cycle During Control Probe Error	10%

\* Hysteresis for units prior to serial number 2044369 in low humidity mode = 1.5 °C.

### Temperature Setpoint

The setpoint is the temperature at which the refrigerator operates.

#### Note

- If the Settings screen is password protected enter appropriate password. If viewing settings for the first time, enter factory default password of "1234".
- Temperature Setpoint can be adjusted through the main Settings screen and Device Control Settings.
- Change the setpoint if your organization requires a chamber temperature other than 4.0 °C.

1. Touch **i.C<sup>3</sup> APPS, i.C<sup>3</sup> Settings**.
2. Enter the Settings password.
3. Touch minus (–) or plus (+) on the **Temperature Setpoint** spin box.

### Hysteresis Setpoint

Hysteresis is the allowable temperature variance on each side of the refrigerator setpoint.

### Delay on Start-Up

Compressor startup is delayed to allow the i.C<sup>3</sup> monitoring and control system to start first.

### Duty Cycle During Control Probe Error

The duty cycle is the percentage of time the compressor will run in the event of a temperature control probe failure.

#### Note

Hysteresis, Delay on Start-up, and Duty Cycle During Control Probe Error are factory-preset and should not be changed unless directed by Helmer Technical Service.

### User Configurable Alarm Settings

The following alarm settings may be changed by the operator. The setpoint for temperature alarms may be changed (where applicable), as well as the time delay between when the alarm condition commences and when the visual and audible alarms are initiated.

**Table 4. User Configurable Alarms**

Alarm	Description	Default Value	Default Time Delay
Primary Monitor Probe High Temp	High temperature at which alarm condition occurs	5.5 °C	0 minutes
Primary Monitor Probe Low Temp	Low temperature at which alarm condition occurs	1.5 °C ( <i>blood bank refrigerators</i> )	0 minutes
		2.0 °C ( <i>pharmacy refrigerators</i> )	
Compressor High Temp	High temperature at which alarm condition occurs	50 °C	0 minutes
Power Failure	Time after power failure occurs until alarm sounds	-	1 minute
Probe Failure	Time after probe failure occurs until alarm sounds	-	0 minutes
Door Open (Time)	Time door remains open until alarm sounds	-	3 minutes
Secondary Monitor Probe High Temp	(if installed) High temperature at which alarm condition occurs	5.5 °C	0 minutes
Secondary Monitor Probe Low Temp		Low temperature at which alarm condition occurs	1.5 °C ( <i>blood bank refrigerators</i> ) 2.0 °C ( <i>pharmacy refrigerators</i> )

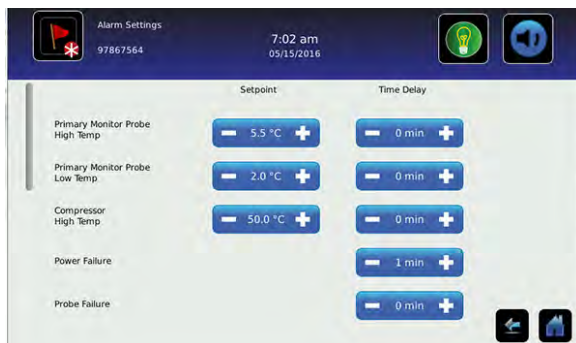

Alarm Settings screen



**Change an Alarm Setting:**

1. Touch **i.C<sup>3</sup> APPS, Settings**.
2. Enter the Settings password (default password is "1234").
3. Scroll down and touch **Alarm Settings**.
4. Touch the minus (-) or plus (+) on the corresponding **Setpoint** spin box to change an alarm setpoint.
5. Touch the minus (-) or plus (+) on the corresponding **Time Delay** spin box to change the time delay duration.
6. Touch **Home** to exit the Alarm Settings screen.



**Non-Configurable Alarms**

The following alarms indicate operational conditions which require the attention of the operator or a qualified service technician.

**Table 5. Non-Configurable Alarm**

Alarm	Description
Low Battery	Rechargeable battery voltage is low
Communication Failure	<p><b>Communication Failure 1</b></p> <ul style="list-style-type: none"> <li>• Triggered if communication is lost between i.C<sup>3</sup> display board and control board</li> <li>• Unit will continue to run with previously saved settings</li> <li>• Screen will not display temperature changes or alarm conditions</li> <li>• i.C<sup>3</sup> system will continue to reset until connection is re-established</li> </ul> <p><b>Communication Failure 2</b></p> <ul style="list-style-type: none"> <li>• Triggered if communication is lost between i.C<sup>3</sup> display board and internal system memory</li> <li>• Unit will continue to run with previously saved settings</li> </ul> <p><b>Communication Failure 3</b></p> <ul style="list-style-type: none"> <li>• Triggered if the database is corrupted</li> <li>• The database is archived and a new database is automatically created</li> <li>• Unit will continue to run with previously saved settings</li> </ul>

### 3.5 Sensor Calibration



Sensor calibration values are programmed at the factory. Calibration values can be viewed and changed through the i.C³ monitoring and control system. To view calibration settings, touch **i.C³ APPS**, **Settings**, and scroll down to **Sensor Calibration**.

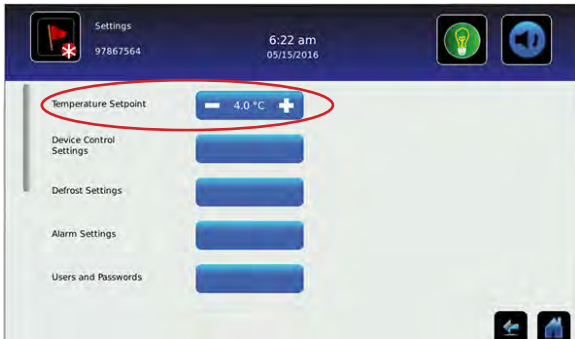

Settings screen



Sensor Calibration screens

#### Notes

- If the Settings screen is password protected enter appropriate password. If viewing settings for the first time, enter factory default password of “1234”.
- After one hour of no interaction, the Home screen or Temperature Graph screensaver (if enabled) is displayed.
- Compressor Probe offset is factory-preset and should not be changed unless directed by Helmer Technical Service.

#### Primary Monitor and Secondary Probes

Verify primary monitor and secondary probes are reading chamber temperature correctly by comparing probe readings to the temperature measured by a calibrated reference thermometer. If the probes are not reading correctly, change the value displayed on the monitor.

The factory default setting for the primary monitor and secondary probes is 4.0°C.

#### Notes

- Ensure product simulation bottle is full of solution.
- Probes in the bottles are connected to the monitoring system and sense chamber temperature. These probes activate the temperature alarms but do not affect refrigerator setpoint.

 **Calibrate Primary Monitor Probe:**

1. Remove primary monitor probe from the upper probe bottle.
2. Unscrew the cap from the bottle.
3. Attach a calibrated independent reference thermometer traceable per national standards to the primary monitor probe, and place them in the bottle. The probe and thermometer should be immersed at least 2" (50 mm).
4. Close the door and allow the chamber temperature to stabilize.
5. Observe and note the thermometer temperature. If the independent thermometer corresponds to the displayed temperature, proceed to **Step 9**.
6. Subtract the displayed temperature reading from the independent probe reading to determine the offset value.
7. Touch, **i.C<sup>3</sup> APPS, Settings, Sensor Calibration**.
8. Touch minus (-) or plus (+) on the corresponding spin box to increase or decrease the value by the value calculated in **Step 6**. The message "New Setting Saved" appears next to the spin box.
9. Remove thermometer from probe.
10. Replace bottle cap, ensuring a tight fit.
11. Place probe in bottle, immersing at least 2" (50 mm).

 **Calibrate Secondary Probe:**

1. Remove secondary probe from the lower probe bottle.
2. Unscrew the cap from the bottle.
3. Attach a calibrated independent reference thermometer traceable per national standards to the secondary probe, and place them in the bottle. The probe and thermometer should be immersed at least 2" (50 mm).
4. Close the door and allow the chamber temperature to stabilize.
5. Observe and note the thermometer temperature. If the independent thermometer corresponds to the displayed temperature, proceed to **Step 9**.
6. Subtract the displayed temperature reading from the independent probe reading to determine the offset value.
7. Touch, **i.C<sup>3</sup> APPS, Settings, Sensor Calibration**.
8. Touch minus (-) or plus (+) on the corresponding spin box to increase or decrease the value by the value calculated in **Step 6**. The message "New Setting Saved" appears next to the spin box.
9. Remove thermometer from probe.
10. Replace bottle cap, ensuring a tight fit.
11. Place probe in bottle, immersing at least 2" (50 mm).

**Control Probe**

The temperature controller senses unit cooler temperature through the control probe in the unit cooler. The unit cooler temperature typically varies from the chamber temperature, so an offset value is used by the control system to compensate for the difference. The temperature controller adjusts chamber temperature around the refrigerator setpoint by activating the compressor when the control probe registers above the setpoint based on the hysteresis value.

 **Determine Control Probe Offset:**

**NOTICE**

- Monitor temperature must be verified and accurate prior to adjusting the Control Probe Offset.

1. View and record the Refrigerator Setpoint.
2. Allow the unit to run with calibrated monitor temperature for several compressor cycles, and record the average monitor temperature.
3. View and record the current Control Offset value.
4. Subtract the Refrigerator Setpoint from the average monitor temperature and record the difference.
5. Add the current Control Offset value to the recorded difference determined in the previous step to establish the new Control Offset value.

Example 1	Example 2
Refrigerator setpoint is 4.0	Refrigerator setpoint is 4.0
Average monitor temperature is 5.2	Average monitor temperature is 2.8
Current Control Offset is 0.3	Current Control Offset is 0.3
Subtract: $5.2 - 4.0 = 1.2$ ; difference between average temperature and setpoint.	Subtract: $2.8 - 4.0 = -1.2$ ; difference between average temperature and setpoint.
Add: $0.3 + 1.2 = 1.5$ ; new control offset value	Add: $0.3 + (-1.2) = -0.9$ ; new control offset value

 **Enter the New Offset Value:**

1. Touch **Home**, **i.C<sup>3</sup> APPS**, **Settings**.
2. Enter the Settings password.
3. Touch **Temperature Calibration**.
4. Touch minus (-) or plus (+) on the **Control Sensor Offset** spin box.
  - ◆ Raise the offset value to lower chamber temperature; lower the offset value to raise chamber temperature.
5. Touch **Home** to return to home screen.

**Compressor Probe**

The compressor probe has been factory-calibrated. Changing the calibration settings is not typically necessary and should not be performed unless directed by Helmer Technical Service.

## Factory Default Settings

Settings listed below may be simultaneously returned to factory default values.

### Note

The factory default settings may not be the same as the settings that were factory-calibrated before the refrigerator was shipped.

**Table 6. Restored Settings**

Setting	Restored Value
Home Screen Application Icons	i.C <sup>3</sup> APPS, Temperature Alarm Test, Temperature Graph, Information Logs, Download
Display Brightness	High (3 symbols)
Password (for Settings screen)	1234
Sounds	On
Alarm Volume	9
Alarm Tone	3
Temperature Calibration Values	Not affected (values previously entered during setup)
Unit ID	Not affected (previously selected during setup)
Date Format	MM/DD/YYYY
Day	Not affected (maintained in real-time clock)
Month	
Year	
Time Format	12-hour
Minute	Not affected (maintained in real-time clock)
Hour	
AM/PM	
Language	
Temperature Units	°C
Password Protection (for Settings screen)	On
Temperature Graph Screensaver	On
Access Control (optional) as Home Page	On
Light Off Delay (on/off)	On
Light Off Delay	5 minutes
High Temperature Alarm Setpoint	5.5 °C
High Temperature Alarm Time Delay	0 minutes
Low Temperature Alarm Setpoint *	1.5 °C (iB models) 2.0 °C (iPR models)
Low Temperature Alarm Time Delay	0 minutes
Power Failure Alarm Time Delay	1 minute
Probe Failure Alarm Time Delay	0 minutes
Door Open (Time) Alarm Time Delay	3 minutes
Compressor Temperature Alarm Setpoint	50.0 °C
Compressor Temperature Alarm Time Delay	0 minutes
Chamber Setpoint	4.0 °C
Chamber Hysteresis	2.0 °C*
Delay on Start-Up	2 minutes
Duty Cycle During Control Probe Error	50%

\* Hysteresis for units prior to serial number 2044369 in low humidity mode = 1.5 °C.

**Additional Factory Default Settings for Models with Low Humidity Option****Table 7. Low Humidity Unit Default Settings**

Setting	Restored Value
Defrost Event #1 On/Off	On
Defrost Event #1 Start Time	12:15 AM
Defrost Event #2 On/Off	On
Defrost Event #2 Start Time	8:00 AM
Defrost Event #3 On/Off	On
Defrost Event #3 Start Time	4:00 PM
Defrost Event #4 On/Off	Off
Defrost Event #4 Start Time	n/a
Defrost Time/Defrost Safety Operation Time	10 minutes

**Note**

Defrost event settings are only applicable to models with the low humidity option.

**Restore Settings:**

1. Touch the **Settings** icon.
2. Scroll down and touch the **Restore Factory Settings** button. The Restore Factory Settings confirmation box appears.
3. Touch  to restore the factory settings or  to maintain the current settings and clear the message.

## 4 Maintenance

Maintenance tasks should be completed according to the schedule below. Refer to the i.C<sup>3</sup> User Guide for more detail on completing the various tasks.

### CAUTION

Maintenance should only be performed by trained refrigeration technicians.

### Notes

- The preventive maintenance schedule provides recommended minimum requirements. Regulations or physical conditions at your organization may require maintenance items be performed more frequently, or only by designated service personnel.
- Before performing maintenance, protect items in refrigerator from extended exposure to adverse temperature.
- Allow refrigerator temperature to stabilize at setpoint after performing service or after extended door opening.

**Table 9. i.Series Preventive Maintenance Schedule**

Task	Frequency			
	Quarterly	1 year	2 years	As Needed
Test the high and low temperature alarms.	✓			
Test the power failure alarm (as required by your organization's protocols).	✓			
Test the door alarm (as required by your organization's protocols).				✓
Check the temperature calibration on the monitor and change it if necessary.	✓			
Check the level of the solution in the probe bottle(s). Refill or replace solution if necessary.				✓
Examine the probe bottle(s) and clean or replace if necessary.		✓		
Clean the condenser grill.	✓			
Clean the door gaskets, interior, and exterior of the refrigerator.				✓
Replace monitoring system back-up battery.			✓	
Inspect ground strap. <small>Units prior to serial number 2022299</small>	✓			
<b>Electrical Compartment</b> <ul style="list-style-type: none"> <li>• Inspect electrical components and wiring terminals in the electrical box for discoloration. Contact Helmer Technical Service if any discoloration is found.</li> <li>• Inspect all wiring terminals for secure connection. Tighten wiring terminal connections as necessary.</li> </ul>	✓			
<b>Models with chart recorders</b> Check the back-up battery for the chart recorder after an extended power failure and change it if necessary, or change the battery if it has been in service for one year. Refer to the Temperature Chart Recorder Operation and Service Manual.				✓

### NOTICE

Clean the condenser grill on a quarterly basis.

### Notes

- During a power failure, the back-up battery provides power to the monitoring system, power failure alarm and the optional i.Lock interlock. If the back-up battery is not functioning, the power failure alarm will not be activated and the battery should be replaced.
- During a power failure, the back-up battery continues to provide power to the optional i.Lock interlock (if equipped). If the back-up battery is not functioning, the optional i.Lock interlock will not secure the door(s).
- If rechargeable battery has been in service for two years, replace battery.

### 4.1 Alarm Tests



Test alarms to ensure they are working correctly. The refrigerator has alarms for chamber temperature, compressor temperature, door open (time), power failure, low battery, and power failure. To initiate alarm tests, touch **i.C³ APPS**, **Temperature Alarm Test**.

#### Automatic Chamber Temperature Alarm Test

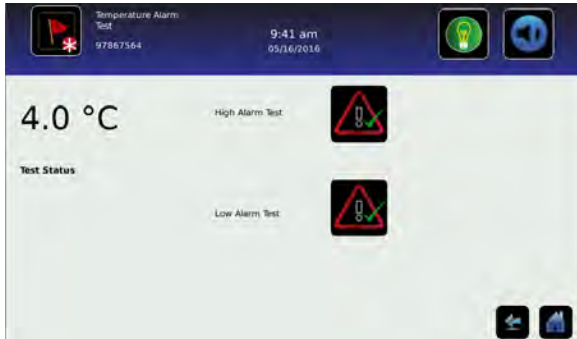

#### Notes

- Test can be aborted by touching **Cancel Test**.
- Test is only applicable to the primary monitor probe.
- Test takes less than five minutes.
- If the temperature alarm test does not complete successfully, restart the i.C³ monitoring system.

When performing an automatic temperature alarm test, the Peltier device heats or cools the primary monitor probe until the high or low alarm setpoint is reached. An event is added to the Event Log to indicate a temperature alarm was activated. The Alarm Test icon is displayed on the Temperature Graph to indicate the temperature alarm was test-induced.

#### Test the Low Alarm:

1. Identify current setting for low alarm setpoint.
2. Touch **Home**, **i.C³ APPS**, **Temperature Alarm Test**.
3. Touch **Low Alarm Test**.
4. "Peltier Test Probe Cooling" message appears.
5. When displayed temperature reaches the alarm setpoint, an alarm is activated.
6. When completed, "Test Complete" appears.
7. Touch **Home**, **i.C³ APPS**, **Information Logs**, **Event Log**. Touch the event to view event details.
8. Observe the temperature at the time of the low temperature alarm event. Compare this to the alarm setpoint.



#### Test the High Alarm:

1. Identify current setting for high alarm setpoint.
2. Touch **Home**, **i.C³ APPS**, **Temperature Alarm Test**.
3. Touch **High Alarm Test**.
4. "Peltier Test Probe Warming" message appears.
5. When displayed temperature reaches the alarm setpoint, the temperature reading turns red.
6. When completed, "Test Complete" appears.
7. Touch **Home**, **i.C³ APPS**, **Information Logs**, **Event Log**. Touch the event to view event details.
8. Observe the temperature at the time of the high temperature alarm event. Compare this to the alarm setpoint.





 **Cancel the Test:**

1. Touch **Cancel Test** icon to end the alarm test. “*Test Stopped*” is displayed in the Test Status section of the display.

 **Note**

When cancelling an automatic test, the message indicating the test is in progress clears immediately. If a setpoint was reached before the test was cancelled, the alarm activates and clears as described earlier.

**Manual Chamber Alarm Test****NOTICE**

- Perform the low alarm test before the high alarm test to control the temperature more closely and complete the testing more quickly.
- Before testing alarms, protect items in the unit from extended exposure to adverse temperature.
- Temperature probes are fragile; handle with care.

 **Test the Low Alarm:**

1. Identify setting for low alarm setpoint.
2. Remove primary monitor probe from bottle.
3. Immerse probe in glass filled with water and crushed ice mixture.
4. When low temperature alarm sounds, note the temperature on the i.C<sup>3</sup> display.
5. Compare the temperature at which the alarm sounds to the low alarm setpoint.

 **Test the High Alarm:**

1. Identify setting for high alarm setpoint.
2. Immerse primary monitor probe in glass of luke warm water.
3. When high temperature alarm sounds, note the temperature on the i.C<sup>3</sup> display.
4. Compare the temperature at which the alarm sounds to the high alarm setpoint.
5. Remove probe from warm water.
6. Place primary monitor probe in probe bottle, immersing it at least 2” (50 mm).

**Power Failure Alarm Test** **Note**

During a power failure, the power failure alarm sounds and the battery provides power to the monitoring system and optional i.Lock interlock.

 **Test Power Failure Alarm**

1. Change Power Failure delay setting to 0 minutes by touching **Settings, Alarm Settings**, then touching minus (-) or plus (+) on the Power Failure spin box to change the value to 0.
2. Switch AC ON/OFF switch OFF. Power failure alarm will activate immediately.
3. Switch AC ON/OFF switch ON. Power failure alarm will clear and audible alarm will cease.
4. Change Power Failure time delay to the original setting.

**Door Open Alarm Test**

1. Change Door Open (Time) delay setting to 0 minutes by touching **Settings, Alarm Settings**, then touching minus (-) or plus (+) on the Door Open (Time) spin box to change the value to 0.
2. Open door. Alarm will activate immediately.
3. Close door. Alarm will clear, and audible alarm will cease.
4. Change the Door Open (Time) setting to the original setting.

**4.2 Upgrade System Firmware**

Helmer may occasionally issue updates for the i.C<sup>3</sup> firmware. Follow upgrade instructions included with the firmware update.

## 4.3 Test and Replace Back-up Batteries

### i.C<sup>3</sup> Monitoring System Back-up Battery

On all i.C<sup>3</sup> screens, the Battery icon will appear in the header bar when the system is running on battery power and the screen brightness will automatically be reduced. The monitoring system will automatically disable some features to extend battery life.

#### Check the i.C<sup>3</sup> Monitoring System Back-up Battery.

1. Turn the AC ON/OFF switch OFF. The screen should continue to display information with reduced brightness and the battery icon will appear on the screen.
2. If the display is blank, replace the battery.
3. Switch AC ON/OFF switch ON.

#### Notes

- The i.C<sup>3</sup> Monitoring System and the optional i.Lock interlock use the same back-up battery.
- Use a battery which meets manufacturer's specifications.

#### Replace Monitoring System Back-up Battery

1. Switch the battery ON/OFF switch **OFF**. Switch the AC ON/OFF switch **OFF**.
2. Disconnect the power wires from the battery terminals.
3. Using a #2 Phillips screwdriver, remove the two screws securing the battery strap to the top of the cabinet.
4. Remove the battery strap and set it aside.
5. Remove the battery from the refrigerator.
6. Place the new battery on the top of the cabinet, in the same orientation as the original battery.
7. Place the battery strap over the battery.
8. Using a #2 Phillips screwdriver, install two screws to attach the battery strap to the top of the cabinet.
9. Connect the power wires to the battery terminals, ensuring the wires are connected to the correct terminals.
10. Switch the AC ON/OFF switch **ON**. Switch the battery ON/OFF switch **ON**.

### Chart Recorder Back-up Battery (if included)

Refer to 360076-1 Temperature Chart Recorder Operation and Service Manual.

## 4.4 Check Probe Bottle

Remove the probe bottle from the bracket and inspect for cracks. Replace the bottle if necessary.

Ensure the probe bottle has approximately 4 oz. (120 mL) of product simulation solution (10:1 ratio of water to glycerin). The glycerin is used to create a solution which simulates the product stored in the refrigerator. The product simulation solution temperature reflects the product's temperature during normal operation. Failure to fill the bottle may prevent the chamber temperature from stabilizing at the temperature setpoint. The probe should be immersed at least 2" (50 mm).

## 4.5 Clean Refrigerator

### Cabinet Exterior

Clean glass surfaces with soft cotton cloth and glass cleaner. Clean exterior surfaces with soft cotton cloth and non-abrasive liquid cleaner.

### Cabinet Interior

Clean painted surfaces with mild detergent. Clean stainless steel surfaces with a general-purpose laboratory cleaner suitable for stainless steel.

### Condenser Grill

#### **CAUTION**

Disconnect refrigerator from AC power when cleaning condenser grill.

If the refrigerator is located in an environment where it is exposed to excessive lint or dust, the condenser grill may require cleaning more frequently than stated in preventive maintenance schedule.

Clean the condenser grill using a soft brush and a vacuum cleaner.

**Door Gasket**

Clean with soft cloth and mild soap and water solution.

**Probe Bottles**** Clean and Refill Probe Bottles**

1. Remove all probes from bottle.
2. Remove bottle from bracket and empty any remaining solution.
3. Clean bottle with a 1:9 ratio of bleach to water solution or a company approved equivalent oxidizing cleaner/disinfectant.
4. Refill bottle with 4 oz. (120 mL) of product simulation solution (10:1 ratio of water to glycerin).
5. Cap bottle tightly to minimize evaporation.
6. Place bottle in bracket.
7. Replace probes, immersing at least 2" (50 mm).

**i.C<sup>3</sup>® Touchscreen**

Clean touchscreen with a soft, dry cotton cloth.

## 5 Service

### 5.1 Refrigerant

**CAUTION**

- Review all safety instructions prior to recharging refrigerant. Refer to **Section 1.1** (Safety).
- Maintenance should only be performed by trained refrigeration technicians.

**Notes**

- Use only non-CFC R134A refrigerant.
- Pressure readings may vary based on chamber temperature and ambient air temperature.
- Normal low side pressures are 16 psi to 18 psi when unit is functioning at standard operating temperatures and measured at the end of the compressor cycle.
- If a refrigerant leak is suspected, Helmer recommends finding and fixing the leak prior to recharging the unit.

Full initial refrigerant charge varies by model and power requirements, which can be found on the product specification label and in the table below.

**Table 8. Refrigerant Charge**

Model	Refrigerant	Power Requirements	Initial Charge
225	R134A	115 V, 60 Hz 230 V, 50 Hz 230 V, 60 Hz	10.1 oz. (286 g)
456	R134A	115 V, 60 Hz 230 V, 50 Hz 230 V, 60 Hz	12.5 oz. (354 g) 10.5 oz. (298 g)*

\* = units with light gray condensing coil



### 5.2 Replace LED Lamp Strip

1. Switch battery switch OFF. Switch AC ON/OFF switch OFF.
2. Using a #2 Phillips screwdriver, remove lamp strip from chamber wall.
3. Unsnap the defective LED and disconnect wires.
4. Snap new LED onto the lamp strip.
5. Connect the wires.
6. Using a screwdriver, attach lamp strip to chamber wall.
7. Switch AC ON/OFF switch ON. Switch battery switch ON.
8. Touch **Light** button or open door to test lamp.
9. Touch **Mute** to disable the high temperature alarm while refrigerator reaches operating temperature.

### 5.3 Remove / Replace Unit Cooler Cover

The unit cooler cover must be removed when servicing the control probe, fan motor(s) or coil.

**NOTICE**

If unit cooler cover is not removed as detailed in this procedure the drain port may be damaged. Improper drainage may result in excessive icing and refrigerator's inability to maintain temperature.

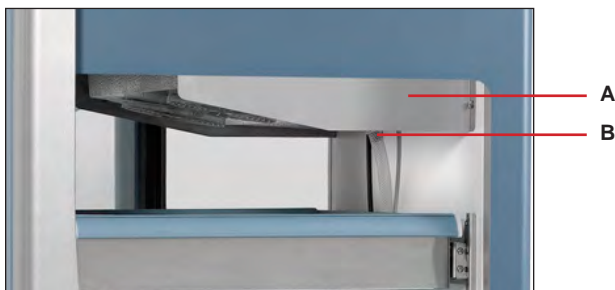

Label	Description
A	Unit cooler cover
B	Drain port

 **Remove Unit Cooler Cover**

1. Switch AC ON/OFF switch OFF. Switch battery switch OFF.
2. Remove top drawer, basket, or shelf from the chamber.
3. Remove drain hose from unit cooler drain port by pulling drain hose downward while gently twisting to remove from drain port.
4. Push the slack in the drain hose aside.
5. Hold unit cooler cover in place to prevent dropping. Using a 5/16" socket wrench, remove four screws securing the unit cooler cover.
6. Carefully lower unit cooler cover to avoid damage to the fan wiring.

 **Install Unit Cooler Cover**

1. Verify unit cooler wiring is connected and routed correctly.
2. Lift unit cooler cover into place. Front edge of the cover should be behind the unit cooler case.
3. Using a 5/16" socket wrench, install four screws to secure the unit cooler cover.
4. In the chamber, attach drain hose to unit cooler drain port.
5. Reinstall top drawer, basket, or shelf if previously removed.
6. Seal the opening around the drain hose on the back of the unit using putty.
7. Switch AC ON/OFF switch ON. Switch battery switch ON.
8. Touch **Mute** to disable the high temperature alarm while refrigerator reaches operating temperature.

## 6 Troubleshooting

### CAUTION

Review all safety instructions prior to troubleshooting. Refer to Section 1.1.

### 6.1 General Operation Problems

Problem	Possible Cause	Action
A drawer or basket does not slide easily	Drawer or basket is misaligned or not level.	Confirm both slides for the drawer or basket are mounted at the same height.
	Drawer slides are not lubricated.	Using a lightweight oil, lubricate the bearings in the slides.
	Debris in the drawer slides.	Pull the drawer or basket out and confirm the slides are free of debris. Clean the slides if necessary.
	Drawer slide is faulty.	Confirm the slide is operating correctly. Replace if necessary.
i.Lock Interlock not working	Key switch is turned OFF.	Turn key switch ON
	Obstruction preventing door to close completely.	Check for obstruction(s) and remove.
	Door switch is broken.	Replace door switch.
A door does not open easily.	Debris in the hinges.	Confirm the hinges are free of debris. Clean the hinges if necessary.
	Door hinges are not lubricated.	Using a general-purpose grease, lubricate the pivots in the hinges.
	Hinge cam is faulty.	Confirm the hinge cam is not damaged. Replace the cam if necessary.
The monitor display is hard to read.	Screen brightness is set too low.	Change the screen brightness.
The chamber temperature meets an alarm condition, but the appropriate temperature alarm is not active.	Temperature alarm setpoint was changed.	Check the current setpoints for the temperature alarms. Change the setpoints if necessary.
The chamber temperature displayed is higher or lower than the actual temperature.	Probe bottles are empty, or the amount of solution is too low.	Check the level of product simulation solution in the bottles. Refill the bottles if necessary.
	Monitor is not calibrated.	Confirm the upper monitor probe is reading correctly. Calibrate the probe if necessary.
	Digital electronics are locked because of an interruption in power.	Reset the monitoring system.
	A component is faulty or internal connections are loose.	Contact Helmer Technical Service.
The chamber temperature does not stabilize at the refrigerator setpoint.	Condenser grill is dirty.	Check the condenser grill. Clean the grill if necessary.
	Air circulation at the top of the chamber is not adequate.	Check if there are any items that may obstruct air flow and remove them if necessary.
	Ambient air temperature around the refrigerator is too high.	Confirm the refrigerator is placed appropriately.
	Refrigerant level is too low.	Check refrigeration lines for leaks and repair if necessary. Check the refrigerant level. Recharge refrigerant if necessary.
	A component is faulty or internal connections are loose.	Contact Helmer Technical Service.
"Probe Failure" is displayed on the monitor.	Temperature probe wiring is an open circuit.	Check the continuity of the probe wiring and connections. Secure the connections if necessary.
		Confirm the probe is providing resistance in the range of 86 Ω to 110 Ω. Replace the probe if necessary.
		Test CP board circuitry by removing the probe connector from the board and placing jumper across jumper pins. Display should show 4 °C +/- 2 °C. Contact Helmer Technical Service.

### 6.2 Chamber Temperature Problems

Problem	Possible Cause	Action
The chamber temperature displayed is higher or lower than the actual temperature.	Probe bottles are empty, or the amount of solution is too low.	Check the level of product simulation solution in the bottles. Refill the bottles if necessary. Refer to the refrigerator operation manual.
	Monitor probe(s) is not calibrated.	Check the chamber temperature calibration. Change calibration if necessary.
	Connections for the monitor probe are loose.	Check the probe connections. Secure the connections if necessary.
The chamber temperature does not stabilize at the refrigerator setpoint.	Control probe is out of calibration.	Confirm the probe is providing accurate temperature readings.
	Control probe is faulty.	Confirm the probe is providing resistance in the range of 98 Ω to 110 Ω. Replace the probe if necessary.
	Unit cooler fan is not running.	Check the voltage to the fan when door switch is activated. Replace the fan motor or door switch if necessary.
	Refrigerant level is too low.	Check the refrigeration lines for leaks and repair them if necessary. Check the refrigerant level. Recharge the refrigerant if necessary.
The compressor runs continuously.	Refrigerator setpoint is set too low.	Confirm the setpoint is set within the operating range. Change if necessary.
	Control probe is out of calibration.	Confirm the probe is providing accurate temperature readings.
	Control probe is faulty.	Confirm the probe is providing resistance in the range of 98 Ω to 110 Ω. Replace the probe if necessary.
	Solid state relay is defective.	Confirm solid state relay is not being commanded on. Replace if necessary.
		Check CP board operation.
Temperature controller board is faulty.	Replace parts with those included in the control board kit, or replace the monitor/control board.	

### 6.3 Alarm Activation Problems

Problem	Possible Cause	Action
The refrigerator is in an alarm condition, but alarms are not audible.	Audible alarms have been muted.	Verify audible alarms are not muted. Touch the Mute button repeatedly until the Mute timer indicates no time delay.
The refrigerator meets an alarm condition, but the appropriate alarm is not active.	Alarm setpoint was changed.	Check the current setpoints for the alarms. Change the setpoints if necessary.
The High Temperature alarm activates when the door is opened, then clears shortly after the door is closed.	Probe bottles are empty.	Check level of product simulation solution in the bottles. Refill bottles if necessary.
	High temperature alarm setpoint is set too low.	Check the setpoint. Change the setpoint if necessary.
	Unit cooler fan continues to run while the door is open.	Test the door switch and unit cooler fan connections. Secure the connections if necessary. Replace the door switch or fan motor if necessary.
	Connections for the monitor probe are loose.	Test the probe connections. Secure the connections if necessary.
	Monitor probe is faulty.	Test the probe. Replace the probe if necessary.
	A component is faulty or internal connections are loose.	Contact Helmer Technical Service.
The refrigerator is connected to power, but the AC Power Failure alarm is active.	ON/OFF AC power switch is OFF.	Turn the ON/OFF AC power switch to the ON position.
	Outlet connection is faulty.	Verify power at the outlet. Repair the original outlet or connect to a different outlet if necessary.
	Power cord is faulty.	Confirm the power cord is connected securely. Secure the power cord if necessary.
	Circuit breaker is tripped. (230V only)	Reset or replace the circuit breaker.
	A component is faulty or internal connections are loose.	Contact Helmer Technical Service.

Problem	Possible Cause	Action
The Door Open alarm is activating sporadically.	Doors are not closing completely.	Confirm the hinge cams are not damaged. Replace the cams if necessary.
	One or more door switches are faulty.	Replace the door switch or switches.
	Temperature monitor/controller board is faulty.	Replace parts with those included in the control board kit, or replace the monitor/control board.
The condenser alarm is active.	Condenser alarm setpoint is too low.	Confirm the alarm setpoint is at the appropriate value.
	Condenser fins are dirty.	Clean as necessary, or order new ones from Helmer or your distributor.
	Compressor is overheating due to a lack of air flow.	Check the condenser grill and clean if necessary.
		Confirm the refrigerator is correctly located. Refer to the operation manual.
	Condenser fan motor is faulty.	Replace the condenser fan motor.
	Connections for the condenser probe are loose.	Check the probe connections. Secure the connections if necessary.
	Condenser probe is faulty.	Test the probe. Replace the probe if necessary.
	Condenser probe is not calibrated.	Confirm the condenser probe is reading correctly. Calibrate the probe if necessary.
A component is faulty or internal connections are loose.	Contact Helmer Technical Service.	
An alarm is activated but the temperature recorded at activation does not match the alarm setpoint.	Temperature monitor is not calibrated.	Confirm the upper monitor probe is reading correctly. Calibrate the probe if necessary.
	Temperature changed slightly around the time of activation.	No action necessary.
The No Battery alarm is activating sporadically.	Battery voltage level on the rechargeable back-up battery for the monitoring system is low.	Replace the back-up battery for the monitoring system.

i.Series Information

### 6.4 Testing Problems

Problem	Possible Cause	Action
The automatic temperature tests do not work.	High Alarm setpoint is set significantly higher than the default value, or the Low Alarm setpoint is set significantly lower than the default value.	Confirm the alarm setpoints are set at the appropriate values.
		Test the temperature alarms manually.
	Connections for the upper monitor probe are loose.	Check the probe connections. Secure the connections if necessary.
	Primary monitor probe is faulty.	Confirm the probe is reading correctly. Calibrate the probe if necessary.
		Confirm the probe is providing resistance in the range of 98 Ω to 110 Ω. Replace the probe if necessary.
Temperature monitor/controller board is faulty.	Replace parts with those included in the control board kit, or replace the monitor/control board.	



### 6.5 Condensation Problems

Problem	Possible Cause	Action
There is excessive water in the water evaporation tray.	Humid air is entering the chamber.	Confirm the refrigerator is level, and the doors are aligned, closing tightly, and sealing correctly. Correct issues as necessary.
	Heater in the evaporation tray is faulty.	Confirm the heater is hot and is drawing the appropriate current. (115 V unit - 0.43 A to 0.55 A current draw; 230 V unit - 0.21 A to 0.35 A current draw)
There is excessive water in the chamber.	Humid air is entering the chamber.	Confirm the refrigerator is level, and the doors are aligned, closing tightly, and sealing correctly. Correct issues as necessary.
	Connection between the unit cooler and the drain tube is loose.	Confirm the connection is secure. Tighten the connection if necessary.
	Drain line is plugged.	Confirm the drain tube is free of debris. Remove debris if necessary.
	Temperature monitor/controller board is faulty.	Contact Helmer Technical Service.
There is excessive humidity on the doors.	Humid air is entering the chamber.	Confirm the refrigerator is level, and the doors are aligned, closing tightly, and sealing correctly. Correct issues as necessary.
	Relative humidity around the refrigerator is too high.	Confirm the refrigerator is placed properly. Refer to the refrigerator operation manual.
Water leaks from the bottom of the refrigerator.	Humid air is entering the chamber.	Confirm the refrigerator is level, and the door is aligned, closing tightly, and sealing correctly.
	Excessive water is found in the evaporation tray inside the refrigerator.	Contact Helmer Technical Service to correct issues as necessary.

## 7 i.Series® Parts

### Notes

- Before replacing parts, protect items in refrigerator from extended exposure to adverse temperature.
- Allow refrigerator temperature to stabilize at setpoint after replacing parts or after extended door opening.
- Circuit boards are sensitive to static electricity and can be damaged by electrostatic discharge. Use proper ESD precautions when handling these boards.
- The condensate evaporator is located below the cabinet and is accessed by removing the evaporator cover on the control side of the refrigerator.



i.Series Information

Letter	Description	Part Number	Volts	Letter	Description	Part Number	Volts
A	Bezel * = without chart recorder door	400999-1	-	J	Skirt (optional, installed on clean room side) * = 2 door models; ** = 4 door models	400862-1*	-
		400998-1*	-			400862-2**	-
B	Door lock	220540	-	K	Upper hinge assembly (i.Center display door; includes pin and bracket) * = Left hinge; ** = Right hinge	400960-2*	-
C	Caster	220467	-			400960-1**	-
D	Temperature Chart Recorder	800026-1	115			400376-2*	-
		800026-2	230	400376-1**	-		
E	Chart recorder door assembly (Blood Bank)	800070-1	-	L	Upper hinge bearing (i.Center display door)	220541	-
F	Chart paper (52 sheets)	220366	-		Upper hinge bearing (without i.Center display)	220375	-
G	Chart recorder back-up battery	120218	-	M	Door gasket	320726-1	-
H	Display assembly	800042-1	-	N	Lower hinge cam (quantity 2)	320742-1	-
Not shown	USB / Power cable for i.Center display	800009-1	-	O	Lower hinge bearing	220375	-
I	Condensate Evaporator Kit	800004-1	115	P	Door stop	320763-1	-
		800212-1	230	Q	Lower hinge bracket * = Right hinge; ** = Left hinge	400377-1*	-
						400377-2**	-

**CAUTION**

Disconnect refrigerator from power when replacing LED lamps.

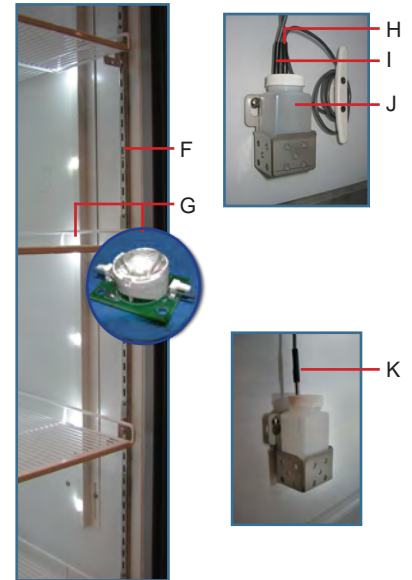
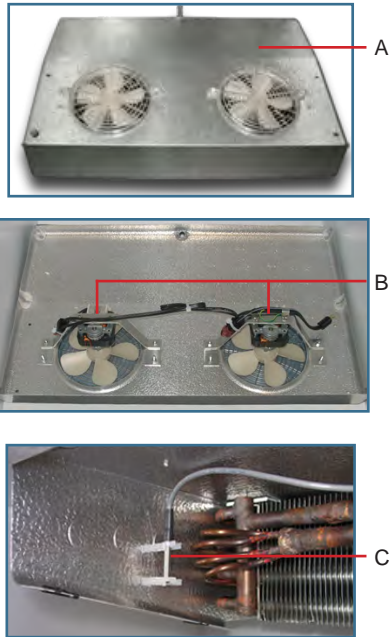

i.Series Information

Letter	Description	Model	Part Number	Volts	Letter	Description	Part Number
A	Unit cooler assembly	225	800831-1	115	Not Shown	Bridge shelf * = 18" depth; ** = 24" depth	400845-1*
		456	800833-1	115			400845-2**
		225	800831-2	230	F	Shelf standard	320733-1
		456	800833-2	230	G	LED lamp	800049-1
B	Unit cooler fan motor	-	800836-1	115	H	Chart recorder probe	800024-1
		-	800835-1	230	I	Primary monitor probe	800038-1
C	Control probe	-	800048-1	-	J	Probe bottle and glycerin kit	400922-1
D	Shelf	-	400857-1	-	K	Secondary monitor probe	800037-1
E	Two-way drawer assembly (Includes drawer with attached slides and hardware)	-	400856-1	-	Not Shown	Door switch	120380
Not Shown	Two-way roll-out basket assembly (Includes drawer with attached slides and hardware)	-	400858-1	-	Not Shown	i.Lock Interlock (optional on iPR models) * glass door	801000-1 801000-2*

**CAUTION**

- Disconnect the refrigerator from AC power before opening the electrical box.

**Note**

The i.C<sup>3</sup> control board is sensitive to static electricity and can be damaged by electrostatic discharge. User proper ESD precautions when handling the board.

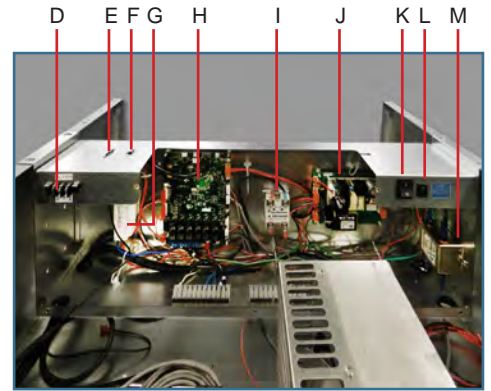
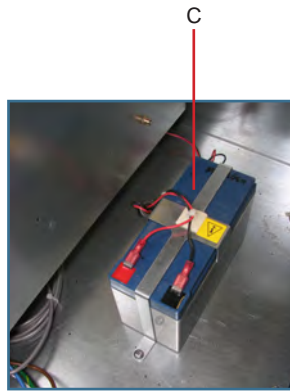
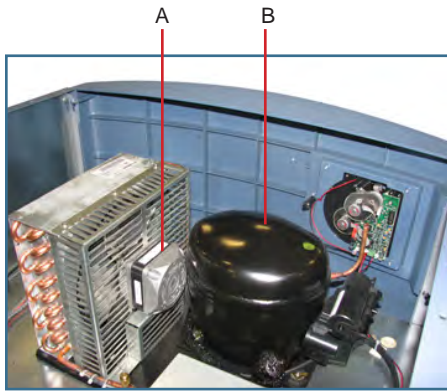

Letter	Description	Model	Part Number	Volts	Hz	Letter	Description	Part Number
A	Condenser fan motor	225	120467	115	-	D	Remote alarm contact	-
		456	120469	115	-	E	USB port	120633
		225	120471	230	-	F	RJ-45 Ethernet port	800008-1
		456	120473	230	-	G	Lighting power supply	120624
B	Compressor	225	400888-1	115	-	H	i.C <sup>3</sup> control board	800034-4
		456	400888-2	115	-	I	Compressor relay	120426
		225	800210-1	230	50	J	Power supply board	800916-1
		456	800211-1	230	50	K	Main power switch	120478
		225	800208-1	230	60	L	Back-up battery switch	120202
		456	800209-1	230	60	M	Power line filter	120400
C	Monitoring system back-up battery	-	120628	-	-	Not Shown	Power cable	120630

## 8 Schematics

### 8.1 iB and iPR Models; 225 and 456 Configurations

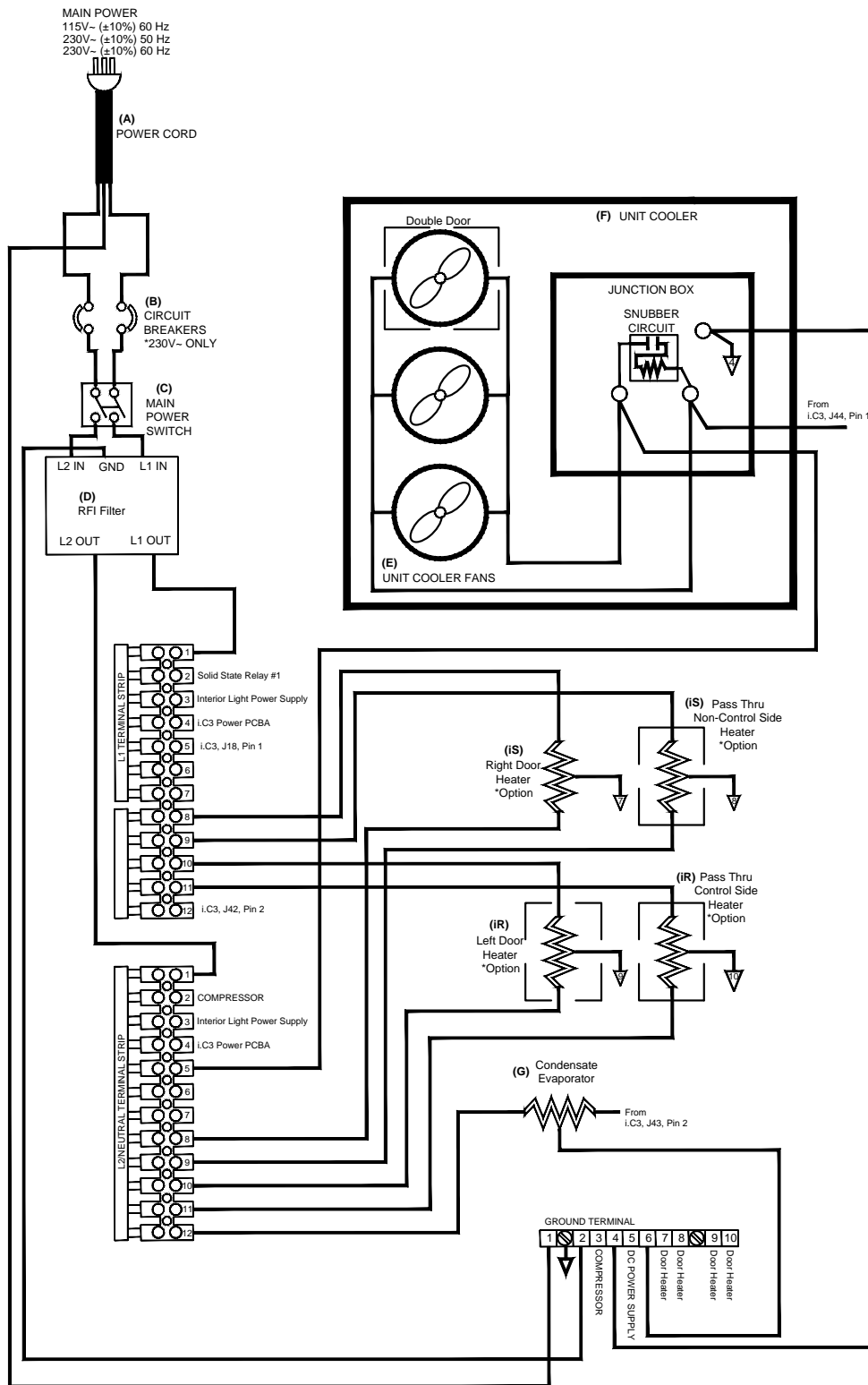

09S039/D

THESE DRAWINGS AND SPECIFICATIONS ARE THE SOLE PROPERTY OF HELMER INC. AND SHALL NOT BE REPRODUCED OR USED AS THE BASIS FOR MANUFACTURE OR SALES OF APPARATUS WITHOUT THE APPROVAL OF HELMER INC.

i.Series Information

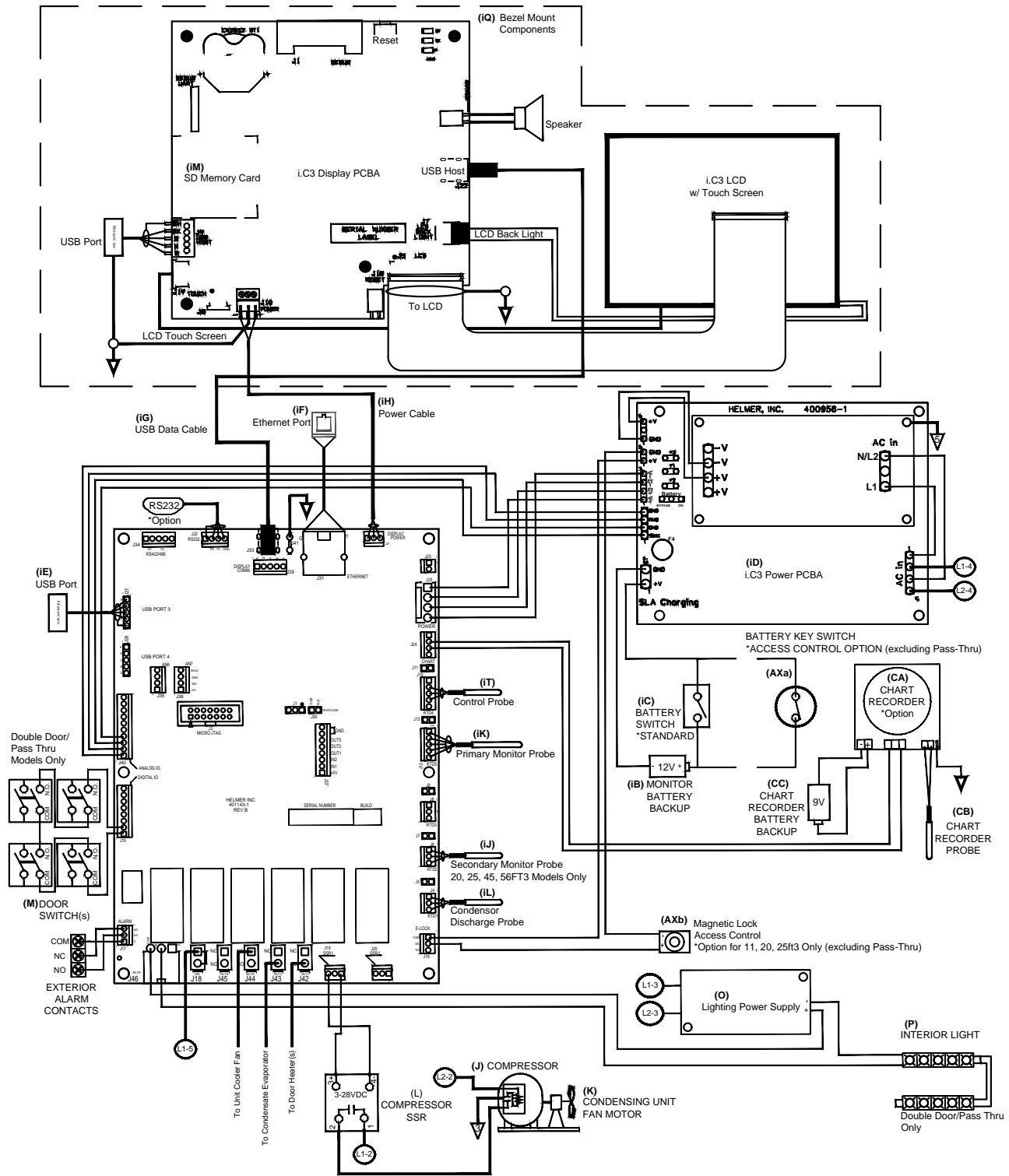

09S039/D

THESE DRAWINGS AND SPECIFICATIONS ARE THE SOLE PROPERTY OF HELMER INC. AND SHALL NOT BE REPRODUCED OR USED AS THE BASIS FOR MANUFACTURE OR SALES OF APPARATUS WITHOUT THE APPROVAL OF HELMER INC.

i.Series Information

8.2 iPR Models; 225 and 456 Configurations with i.Lock™ Interlock

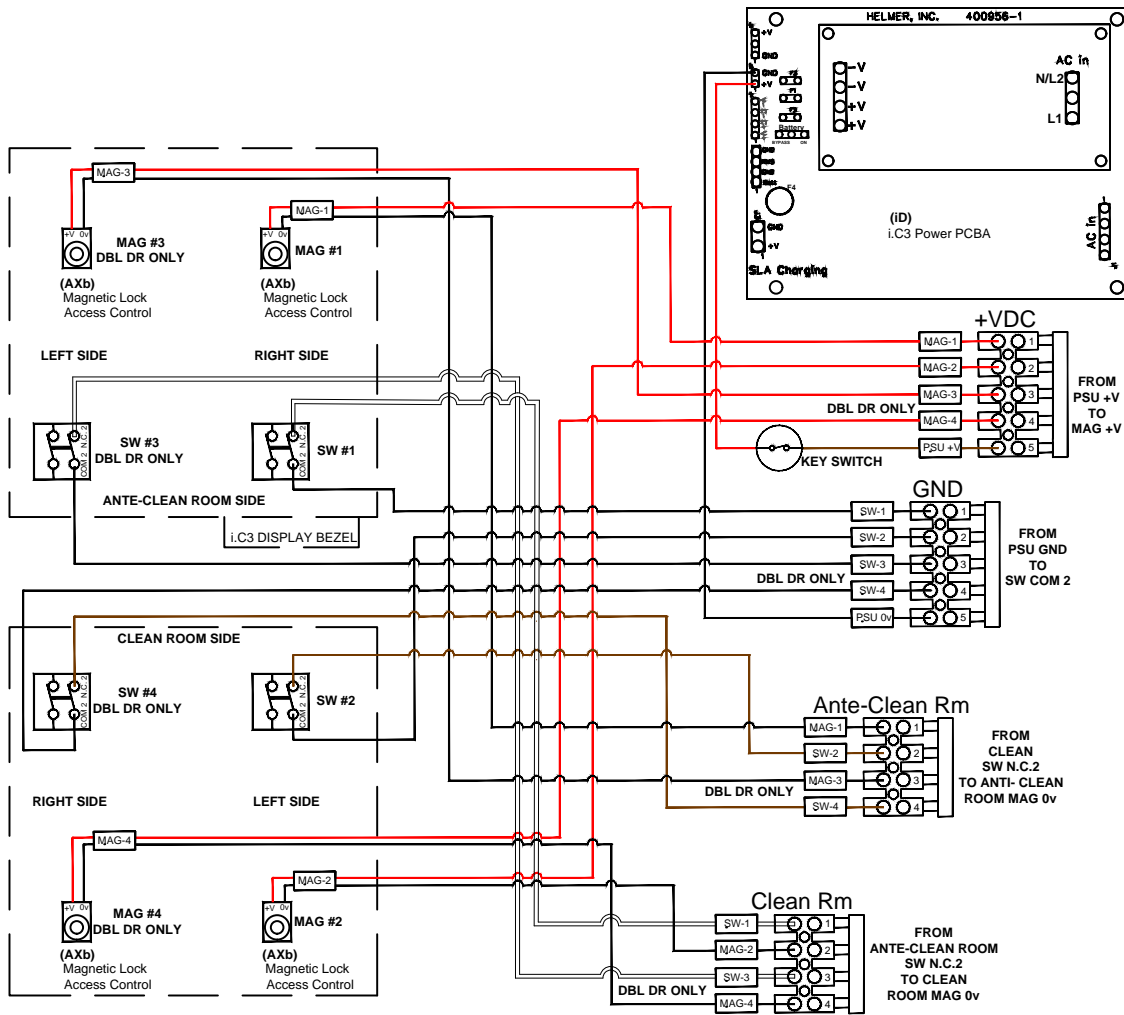

09S039/D

THESE DRAWINGS AND SPECIFICATIONS ARE THE SOLE PROPERTY OF HELMER INC. AND SHALL NOT BE REPRODUCED OR USED AS THE BASIS FOR MANUFACTURE OR SALES OF APPARATUS WITHOUT THE APPROVAL OF HELMER INC.

i.Series Information

## Horizon Series™ Information

### 9 Installation and Configuration

#### 9.1 Location Requirements

- ◆ Grounded outlet meeting the electrical requirements listed on the product specification label.
- ◆ Clear of direct sunlight, high temperature sources, and heating and air conditioning vents.
- ◆ Meets limits specified for ambient temperature (15°C to 32°C) and relative humidity.
- ◆ Minimum 8" (203 mm) above.
- ◆ Clearance above the clean room side may be 0".
- ◆ Top enclosure cannot be placed more than 11" (280 mm) from the front (clean room side) of the refrigerator.
- ◆ Side enclosures may be flush with both sides of the refrigerator.

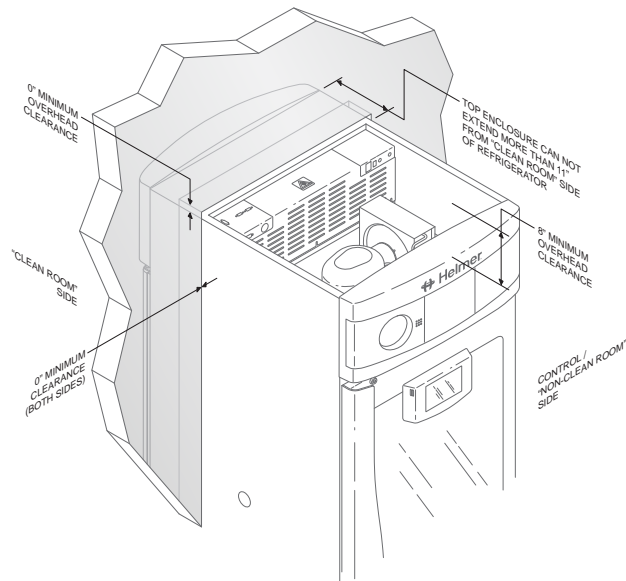

#### 9.2 Placement and Leveling

##### CAUTION

- To prevent tipping, ensure the casters are unlocked and doors are closed before moving the refrigerator.

- ◆ Roll refrigerator into place and lock casters.
- ◆ Ensure refrigerator is level.



### 9.3 Connect Back-Up Power

The monitoring system has a back-up battery system, enabling a period of continuous operation if power is lost. Battery life varies by manufacturer as well as voltage level remaining. Providing full battery power is available, back-up power for the monitoring system is available for up to two hours.

#### Note

The monitoring system will start on back-up battery power alone. If the refrigerator was not previously connected to AC power and the back-up battery is connected, the monitoring system will begin running on battery power.

The back-up battery is located on the top of the refrigerator.

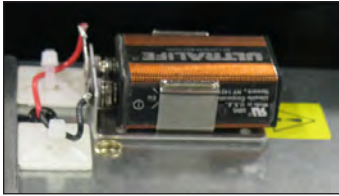

*Monitoring system back-up battery*

### 9.4 Prepare for Monitoring

The monitoring system back-up battery is included in the accessory package. Install and connect the battery to provide the monitoring system with back-up power in the event of AC power failure.

#### Temperature Probes

#### Notes

- Temperature probes are fragile; handle with care.
- The number and location of probes varies by model.
- Remote probes may also be introduced through the existing top ports, and immersed in existing probe bottles.

The number and location of probes varies by model. External probes may be introduced through the existing top ports and immersed in existing probe bottles.

Probe bottle(s) along with a container of glycerin have been provided with this unit. The glycerin is used to create a solution which simulates the product stored in the refrigerator. The product simulation solution temperature reflects the product's temperature during normal operation.

Each probe bottle should contain 4 oz. (120 mL) of product simulation solution at a 10:1 ratio of water to glycerin.



*Left: Probe bottle with temperature and chart recorder probes.  
Right: Top access port.*

#### Fill Probe Bottle

1. Remove all probes from bottle and remove bottle from bracket.
2. Remove cap and fill with 4 oz. (120 mL) of product simulation solution.
3. Install cap and place bottle in bracket.
4. Replace probes, immersing at least 2" (50 mm) in solution.

### ✔ Install Additional Probe Through Top Port

1. Peel back putty to expose port.
2. Insert probe through port into chamber.
3. Insert probe into bottle.
4. Replace putty, ensuring a tight seal.

### Chart Recorder (if included)

The chart recorder has a back-up battery system, enabling a period of continuous operation if power is lost. Battery life varies by manufacturer as well as voltage level remaining. Providing full power is available, back-up power for the temperature chart recorder is available for up to 14 hours.

#### **i** Note

- If chart recorder has been operating on back-up battery power, the battery should be replaced to ensure the back-up source has proper charge.
- For complete information, refer to the Temperature Chart Recorder Operation and Service Manual included with this unit.

### Prior to use:

Place probe in bottle with primary monitor probe.

### Set up and Operation

Access chart recorder by pulling the door open.



Horizon Series chart door

### ✔ Install Battery

Connect the leads to the battery to provide back-up power to the chart recorder.

### ✔ Install / Replace Chart Paper

#### **i** Notes

- For accurate temperature reading, ensure the current time is aligned with the time line groove when chart knob is tightened.



Chart recorder stylus and time line groove

1. Press and hold **C** button. When stylus begins to move left, release button. The LED flashes.
2. When stylus stops moving, remove chart knob then move knob up and away.
3. Place chart paper on chart recorder.
4. Gently lift stylus and rotate paper so current time line corresponds to time line groove.
5. Hold chart paper in place while making sure the chart knob is fully tightened. *(Failure to fully tighten the knob can result in paper slipping and losing time.)*
6. Press and hold **C** button. When stylus begins to move right, release button.
7. Confirm stylus is marking on paper and stops at the correct temperature.
8. Calibrate chart recorder to match primary temperature if needed and close recorder door.

## External Monitoring Devices

The remote alarm interface is a relay switch with 3 terminals:

- ◆ Common (COM)
- ◆ Normally Open (NO)
- ◆ Normally Closed (NC)

Terminals are dry contacts and do not supply voltage. Interface circuit is either normally open or normally closed, depending on terminals used.

Requirements for your alarm system determine which alarm wires must connect to terminals.

### CAUTION

- The interface on the remote alarm monitoring system is intended for connection to the end user's central alarm system(s) that uses normally open or normally closed dry contacts.
- If an external power supply exceeding 30 V (RMS) or 60 V (DC) is connected to the remote alarm monitoring system's circuit, the remote alarm will not function properly and may cause damage to the control board or result in injury to the user.

The terminals on the remote alarm interface have the following maximum load capacity:

- ◆ 0.25 A at 30 V (RMS)
- ◆ 0.25 A at 60 V (DC)

### Connect to Remote Alarm Interface

1. On the electrical box, locate the remote alarm terminals.
2. Connect remote alarm wires to appropriate terminals, according to requirements for your alarm system.
3. Use a cable tie to relieve strain on alarm wires (as necessary).

## 9.5 Configure Storage

### CAUTION

- Before moving drawers, ensure they are completely empty for safe lifting.
- Maximum basket, drawer, or shelf load is 100 lbs (46 kg).

### Note

Before moving storage components, protect stored items in refrigerator from extended exposure to adverse temperature.

### Product Loading Guidelines

When loading your refrigerator, take care to observe the following guidelines:

- ◆ Never load refrigerators beyond capacity.
- ◆ Always store items within shelves, drawers or baskets.
- ◆ Temperature uniformity is maintained by air circulation, which could be impeded if unit is overfilled, particularly at the top or against the doors or walls. Ensure proper clearance is provided below the fan.

### Note

Products stacked against walls or doors may obstruct air flow and affect performance of unit.

### Drawers and Baskets

#### Remove a drawer or basket

1. Pull drawer or basket out until it stops.
2. Tilt the front of the drawer or basket upward.
3. Pull drawer or basket free of the slides.

#### Install a drawer or basket

1. Align end guides on drawer or basket with the slides.
2. Gently push drawer or basket into chamber until it stops.
3. Pull drawer or basket out until it stops; check for smooth operation.

**☑ Move drawer slides**

1. Using a screwdriver, remove front bracket retainers.
2. Tap front brackets upward to disengage standards.
3. Remove slides from standards
4. Insert slides into standard at appropriate height.
5. Tap front brackets downward to engage standards.
6. Using a screwdriver, install front bracket retainers.

**Shelves****☑ Remove a shelf**

1. With one hand, lift front edge of the shelf from the front brackets.
2. With the other hand, reach under the shelf and bump rear edge of the shelf upward to disengage rear brackets.

**☑ Install a shelf**

1. Insert shelf into chamber, placing it on brackets.
2. Gently bump rear edge of the shelf downward to engage brackets.
3. Pulling shelf forward gently; shelf should not disengage from rear brackets.

**☑ Move shelf brackets**

1. Using a screwdriver, remove front bracket retainers.
2. Tap front brackets upward to disengage standards.
3. Remove front brackets from standards.
4. Insert front brackets into standard at appropriate height.
5. Tap front brackets downward to engage standards.
6. Using a screwdriver, install front bracket retainers.

**9.6 Optional Adapter Kits for Medication Dispensing Locks**

Contact Helmer Technical Service or your distributor for service documentation pertaining to medication dispensing locks.

## 10 Controls

Horizon Series models are equipped with a monitor and control system which allows users to view and change current settings.

### 10.1 Monitor and Control Interface

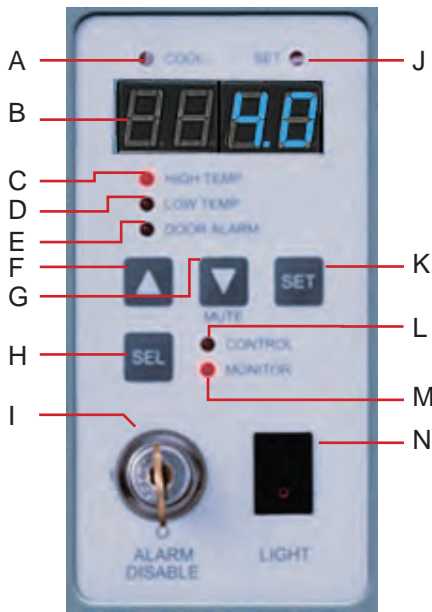

Table 9. Monitor and Control Indications

Label	Description	Function
A	COOL lamp	Indicates the compressor is running.
B	LED Display	Displays real-time and stored temperature information, setpoints, and alarms.
C	HIGH TEMP lamp	Indicates when the refrigerator is in a high temperature alarm condition. Also indicates the high alarm temperature setpoint is being changed.
D	LOW TEMP lamp	Indicates when the refrigerator is in a low temperature alarm condition. Also indicates the low alarm temperature setpoint is being changed.
E	DOOR ALARM lamp	Indicates when the door is open.
F	UP ARROW button	Increases a temperature setting.
G	DOWN ARROW button	Decreases a temperature setting. Also mutes the audible alarm for 5 minutes.
H	SEL button	Toggles between alarm monitor and control modes.
I	ALARM DISABLE key switch	Disables all audible alarms. Does not affect alarm lamps or signals sent through the remote alarm interface.
J	SET lamp	Indicates when temperature setpoint or alarm setpoint is being changed.
K	SET button	Allows settings to be selected, prior to changing settings.
L	CONTROL lamp	Indicates when the reading from the control probe is displayed.
M	MONITOR lamp	Indicates when the display is showing temperature readings from the monitor probe. Also indicates when alarm setpoints are being changed.
N	LIGHT switch	Turns the chamber light on or off.

## Display Minimum and Maximum Monitor Temperature Recordings

### Notes

- This feature is standard on Horizon Series™ models with serial numbers of 2015494 or higher. Some exceptions may exist. For confirmation on your unit, please contact Helmer Technical Service.
- Units that do not include the minimum and maximum recording feature will not display .C or .F when entering the program mode. All temperature readings will appear in .C only.
- The following steps only apply to the primary monitor probe.

The minimum and maximum recording feature allows the user to view a minimum temperature occurrence and a maximum temperature occurrence within a given period of time. The timer provides a time reference in which those temperatures occurred.

### View *minimum* temperature recording.

- ◆ Press and hold the **Down Arrow** button for 1 second and listen for a single beep. 
- ◆ The display will alternate between **LO** and a valid temperature value five (5) times followed by a single beep to indicate exit back to the temperature display.



### View *maximum* temperature recording.

- ◆ Press and hold the **Up Arrow** button for 1 second and listen for a single beep. 
- ◆ The display will alternate between **HI** and a valid temperature value five (5) times followed by a single beep to indicate exit back to the temperature display.



### View recorded temperature timer.

#### Notes

- The timer denotes the period of time that has elapsed. It does not display the time at which a minimum or maximum temperature occurred.
- The maximum period of time the timer can record is 99:59 (99 hours and 59 minutes).

- ◆ Press and hold either the **Up** or **Down Arrow** button for 1 second.  or 
- ◆ While the display is flashing the **HI** or **LO** value, press and hold the **SET** button for 1 second.
- ◆ The display will alternate five (5) times between **CLr** and a value representing the number of hours and minutes that have elapsed since the last recording (example: 12:47 would represent 12 hours and 47 minutes). A single beep will follow to indicate exit back to temperature display.

### Clear minimum and maximum temperature recordings.

- ◆ Press and hold either the **Up** or **Down Arrow** button for 1 second.  or 
- ◆ While the display is flashing the **HI** or **LO** value, press and hold the **SET** button for 1 second and listen for a single beep.
- ◆ While the display is flashing the elapsed time since last reset, press and hold the **SET** button for 2 seconds. **CLr** will be displayed followed by a series of 3 beeps to indicate exit back to the temperature display.

#### Notes

The minimum and maximum temperature and timer will reset when:

- the unit is powered off and battery back-up is not engaged, or
- after 99 hours and 59 minutes have elapsed.

### 10.2 Alarm Reference

If an alarm condition is met, an alarm activates. Some alarms are visual only; others are visual and audible. Some alarms are sent through the remote alarm interface.

The table indicates if an alarm is audible (A), visual (V), or sent through the remote alarm interface (R).

**Table 10. Alarm Indications**

Alarm	Alarm Type
High Temperature	A, V, R
Low Temperature	A, V, R
Door Open (Time)	A, V, R
Power Failure	A, V, R
Probe Failure	A, V, R

### 10.3 Settings

#### Temperature Settings

Temperature settings are factory pre-set. Settings can be viewed and changed through the Monitor and Control interface.

**Table 11. Parameters, Indicators and Settings**

Parameter	Visual Indicator	Range	Default
Celsius or Fahrenheit	TEMPERATURE UNITS, LED display	.C, .F	.C
High Temperature	MONITOR Lamp & HIGH Lamp	-40.0 to 25.0 (°C) -40 to 77 (°F)	5.5 °C
Low Temperature	MONITOR Lamp & LOW Lamp	-40.0 to 25.0 (°C) -40 to 77 (°F)	1.5 °C (HB); 2.0 °C (HPR)
Monitor Offset	MONITOR Lamp only	-10.0 to 10.0 (°C) -18 to 18 (°F)	Varies
Control Offset	CONTROL Lamp only	-10.0 to 10.0 (°C) -18 to 18 (°F)	Varies
Hysteresis	CONTROL Lamp only <i>(units prior to serial number 2051485)</i>	0.5 to 2.5 (°C) 1 to 5 (°F)	2.0 °C*
	COOL Lamp only <i>(units with serial number 2051485 and greater)</i>		

\* Hysteresis for units prior to serial number 2044369 in low humidity mode = 1.5 °C.

#### View settings and offset values

1. Press and hold the **Up** and **Down Arrows** simultaneously for 3 seconds to enter program mode.
2. The LED Display will show .C or .F to indicate Celsius or Fahrenheit.
3. Press and release **SEL** to scroll through the parameters and view settings.
4. Hold **Up** and **Down Arrows** simultaneously for 3 seconds to exit program mode.
5. The LED Display will show current monitor temperature.

## Temperature setpoint

The default setpoint for the refrigerator is 4.0 °C. This can be changed if your organization requires a chamber temperature other than 4.0 °C.

### Change setpoint:

#### Note

The current temperature setpoint is typically higher than the chamber temperature.

1. On the monitoring system, press and release **SEL** to change to Control mode. The CONTROL lamp will illuminate.
2. Press and hold **SET** to display the current temperature setpoint.
3. Hold **SET** and press **Up or Down Arrow** as necessary to set the desired value.
4. Release **SET** button. The new setting is saved.
5. Press and release **SEL** to return to Monitor mode. The MONITOR lamp will illuminate.

## Temperature Units

#### Note

If temperature units are changed, the temperature setpoints, offsets and alarm settings must be recalibrated.

### Select temperature units

1. Press and hold the **Up** and **Down Arrows** simultaneously for 3 seconds to enter program mode.
2. The LED Display will show .C or .F to indicate Celsius or Fahrenheit.
3. Press and hold the **SET** button while pressing the **Up** or **Down Arrow** to select the desired temperature unit parameter.
4. Release **SET** button. The new setting is saved.
5. Press and hold **Up** and **Down Arrows** simultaneously for 3 seconds to exit program mode.

## Alarm Settings

The high and low temperature alarm settings may be changed by the operator. Temperature alarm setpoints specify the temperature at which an alarm activates. The setpoint for temperature alarms may be changed.

### High Temperature Alarm

#### Change the alarm setpoint

1. Press and hold the **Up** and **Down Arrows** simultaneously for 3 seconds to enter program mode.
2. The LED Display will show .C or .F to indicate Celsius or Fahrenheit.
3. Press **SEL** until HIGH TEMP and MONITOR lamps flash.
4. Hold **SET**, then press **Up** or **Down Arrow** to change the setpoint.
5. Release **SET** button. The new setting is saved.
6. Press and hold **Up** and **Down Arrows** simultaneously for 3 seconds to exit program mode.

### Low Temperature Alarm

#### Change the alarm setpoint

1. Press and hold the **Up** and **Down Arrows** simultaneously for 3 seconds to enter program mode.
2. The LED Display will show .C or .F to indicate Celsius or Fahrenheit.
3. Press **SEL** until LOW TEMP and MONITOR lamps flash.
4. Hold **SET**, then press **Up** or **Down Arrow** to change the setpoint.
5. Release **SET** button. The new setting is saved.
6. Press and hold **Up** and **Down Arrows** simultaneously for 3 seconds to exit program mode.



## Primary Monitor Probe

Verify the primary monitor probe is reading chamber temperature correctly by comparing primary monitor probe readings to the temperature measured by a calibrated reference thermometer. If the primary monitor probe is not reading correctly, change the monitor offset value displayed.

### Notes

- Ensure product simulation bottle is full of solution.
- The probe in the bottle is connected to the monitoring system and represents product storage temperature. This probe does not affect the refrigerator setpoint.

### Calibrate primary monitor probe:

1. Remove primary monitor probe from probe bottle.
2. Unscrew cap from the bottle and remove.
3. Attach a calibrated independent reference thermometer traceable per national standards to the primary monitor probe. Place them in the bottle, and close the door. The probe and thermometer should be immersed at least 2" (50 mm).
4. Observe and note the thermometer temperature. If the independent thermometer corresponds to the displayed temperature, proceed to **Step 6**.
5. Adjust the monitor offset value higher or lower to reflect the difference between the chamber temperature displayed on the monitor and the temperature reading from the calibrated reference thermometer.
6. Remove reference thermometer from probe.
7. Replace the bottle cap, ensuring a tight fit.
8. Place primary monitor probe in bottle, immersing at least 2" (50 mm).

### Enter the new offset value:

1. Press and hold the **Up** and **Down Arrows** simultaneously for 3 seconds to enter program mode.
2. The display will show .C or .F to indicate Celsius or Fahrenheit.
3. Press **SEL** until only the MONITOR lamp flashes.
4. Hold **SET**, then press **Up** or **Down Arrow** to change the monitor offset.
5. Release **SET** button. The new setting is saved.
6. Press and hold **Up** and **Down Arrows** simultaneously for 3 seconds to exit program mode.

## Control Sensor

The temperature controller senses unit cooler temperature through the control probe in the unit cooler. The unit cooler temperature typically varies from the chamber temperature, so an offset value is used by the control system to compensate for the difference. The temperature controller adjusts chamber temperature around the refrigerator setpoint by activating the compressor when the control probe registers above the setpoint based on the hysteresis value.

### Determine control sensor offset:

### Notes

- Control Sensor Offset is factory-preset and changing this value is not recommended. Contact Helmer Technical Service for questions regarding the Control Sensor Offset.
1. View and record the Refrigerator Setpoint. (Reference Section 10.3)
  2. Allow the unit to run with calibrated monitor temperature for several compressor cycles, and record the average monitor temperature. *(If the monitor temperature remains close to the refrigerator setpoint no further action is needed.)*
  3. View and record the current Control Offset value.
  4. Subtract the Refrigerator Setpoint from the average monitor temperature and record the difference.
  5. Add the current Control Offset value to the recorded difference determined in the previous step to establish the new Control Offset value.

Example 1	Example 2
Refrigerator setpoint is 4.0	Refrigerator setpoint is 4.0
Average monitor temperature is 5.2	Average monitor temperature is 2.8
Current Control Offset is 0.3	Current Control Offset is 0.3
Subtract: $5.2 - 4.0 = 1.2$ ; difference between average temperature and setpoint.	Subtract: $2.8 - 4.0 = -1.2$ ; difference between average temperature and setpoint.
Add: $0.3 + 1.2 = 1.5$ ; new control offset value	Add: $0.3 + (-1.2) = -0.9$ ; new control offset value

 **Enter the new offset value:**

 **Notes**

- Ensure Control Sensor Offset is being changed, and not Hysteresis.
- Control Sensor Offset and Hysteresis have the same visual indicator.

1. Press and hold the **Up** and **Down Arrows** simultaneously for 3 seconds to enter program mode.
2. The Display will show .C or .F to indicate Celsius or Fahrenheit.
3. Press **SEL** until only the CONTROL lamp flashes.
4. Hold **SET**, then press **Up** or **Down Arrow** to change the setpoint.
5. Release **SET** button. The new setting is saved.
6. Press and hold **Up** and **Down Arrows** simultaneously for 3 seconds to exit program mode.

**Hysteresis**

Hysteresis is the allowable temperature control variance on each side of the refrigerator setpoint.

 **Note**

The Hysteresis value is factory-preset and should not be changed unless directed by Helmer Technical Service.

**Non-Configurable Alarms**

The Power Failure and Door Open alarms indicate operational conditions which may require the attention of the operator or a qualified service technician. The Power Failure alarm will activate immediately upon loss of power. The Door Open alarm will activate once the door has remained open for approximately three minutes. These settings are factory-preset and may not be changed.

## 11 Maintenance

Maintenance tasks should be completed according to the schedule below. Refer to the service manual for more detail on the various tasks.

**CAUTION**

- Review all safety instructions prior to recharging refrigerant. Refer to **Section 1.1(Safety)**.
- Maintenance should only be performed by trained refrigeration technicians.

**Notes**

- The preventive maintenance schedule provides recommended minimum requirements. Regulations or physical conditions at your organization may require maintenance items to be performed more frequently, or only by designated service personnel.
- Before performing maintenance, protect items in refrigerator from extended exposure to adverse temperature.
- Allow refrigerator temperature to stabilize at setpoint after performing service or after extended door opening.

**Table 11. Horizon Series Preventive Maintenance Schedule**

Task	Frequency		
	Quarterly	1 year	As Needed
Test the high and low temperature alarms.	✓		
Test the power failure alarm.	✓		
Test the door alarm (as required by your organization's protocols).			✓
Check the temperature calibration on the monitor and change it if necessary.	✓		
Check the level of the solution in the probe bottle(s). Refill or replace solution if necessary.			✓
Examine the probe bottle(s) and clean or replace if necessary.		✓	
Clean the condenser grill.	✓		
Clean the door gaskets, interior, and exterior of the refrigerator.			✓
Replace monitoring system back-up battery.		✓	
<b>Electrical Compartment</b> <ul style="list-style-type: none"> <li>• Inspect electrical components and wiring terminals in the electrical box for discoloration. Contact Helmer Technical Service if any discoloration is found.</li> <li>• Inspect all wiring terminals for secure connection. Tighten wiring terminal connections as necessary.</li> </ul>	✓		
<b>Models with chart recorders</b> Check the back-up battery for the chart recorder after an extended power failure and change it if necessary, or change the battery if it has been in service for one year. Refer to the Temperature Chart Recorder Operation and Service Manual.			✓

**NOTICE**

Clean the condenser grill on a quarterly basis.

**Notes**

- During a power failure, the back-up battery provides power to the monitoring system and the power failure alarm. If the back-up battery is not functioning, the power failure alarm will not be activated.
- If the back-up battery does not provide power to the monitoring system during the power failure alarm test, replace the battery.

## 11.1 Alarm Tests

Test alarms to ensure they are working correctly. The refrigerator has alarms for chamber temperature, power failure, and door open (time).

### Chamber Temperature Alarm Test

#### NOTICE

- Perform the low alarm test before the high alarm test to control the temperature more closely and complete the testing more quickly.
- Before testing alarms, protect items stored in the unit from extended exposure to adverse temperature.
- Temperature probes are fragile; handle with care.

#### Test the Low Alarm:

1. Identify setting for low alarm setpoint.
2. Remove primary monitor probe from bottle.
3. Immerse probe in glass filled with water and crushed ice mixture.
4. When low temperature alarm sounds, note the temperature on the LED display.

#### Test the High Alarm:

1. Identify setting for high alarm setpoint
2. Immerse probe in glass of lukewarm water.
3. When high temperature alarm sounds, note the temperature on the LED display.
4. Remove probe from warm water.
5. Place primary monitor probe in probe bottle, immersing it at least 2" (50 mm).

### Power Failure Alarm Test

#### Note

During a power failure, the back-up battery should continue to provide power to the monitoring system.

#### Test Power Failure Alarm

1. Switch AC ON/OFF switch OFF. Audible power failure alarm will activate immediately and "PoFF" (power off) will appear on the display.
2. Switch AC ON/OFF switch ON. Audible power failure alarm will cease and "PoFF" will clear from the display.

### Door Open Alarm Test

#### Note

Factory-set to three minutes and can not be changed.

#### Test Door Open Alarm

1. Open refrigerator door and note the time.
2. After three minutes, audible alarm will activate and DOOR ALARM lamp will flash.
3. Close refrigerator door. Audible door open alarm will cease and DOOR ALARM lamp will stop flashing.

## 11.2 Test and Replace Back-up Batteries

### Check Monitoring System Battery

The monitoring system does not indicate the charge level of the battery. Regularly test the battery and replace if the test fails or if the battery has been in use for one year.

 **Note**

Use only a battery which meets manufacturer's specifications.

 **Test Battery:**

1. Switch the AC ON/OFF switch OFF.
2. Display should continue to display information and the No Battery alarm should activate.
3. If the display is blank, replace battery.
4. Switch AC ON/OFF switch ON.

 **Replace Battery**

1. Disconnect the existing battery and remove from the retaining clip.
2. Install new battery in retaining clip and reconnect to snap connector.

### Chart Recorder Back-up Battery (if included)

Refer to 360076-1 Temperature Chart Recorder Operation and Service Manual.

## 11.3 Check Probe Bottle

Remove the probe bottle from the bracket and inspect for cracks. Replace the bottle if necessary.

Ensure the probe bottle has approximately 4 oz. (120 mL) of product simulation solution (10:1 ratio of water to glycerin). The glycerin is used to create a solution which simulates the product stored in the refrigerator. The product simulation solution temperature reflects the product's temperature during normal operation. Failure to fill the bottle may prevent the chamber temperature from stabilizing at the temperature setpoint. The probe should be immersed at least 2" (50 mm).

## 11.4 Clean the Refrigerator

### Cabinet Exterior

Clean glass surfaces with soft cotton cloth and glass cleaner. Clean exterior surfaces with soft cotton cloth and non-abrasive liquid cleaner.

### Cabinet Interior

Clean painted surfaces with mild detergent. Clean stainless steel surfaces with a general-purpose laboratory cleaner suitable for stainless steel.

### Condenser Grill

**CAUTION**

Disconnect refrigerator from AC power when cleaning condenser grill.

If the refrigerator is located in an environment where it is exposed to excessive lint or dust, the condenser grill may require cleaning more frequently than stated in preventive maintenance schedule.

Clean the condenser grill using a soft brush and a vacuum cleaner.

### Door Gaskets

Clean with soft cloth and mild soap and water solution.

**Probe Bottles**** Clean and Refill Probe Bottles**

1. Remove all probes from bottle.
2. Remove bottle from bracket and empty any remaining solution
3. Clean bottle with a 1:9 ratio of bleach to water solution or a company approved equivalent oxidizing cleaner/disinfectant.
4. Refill bottle with 4 oz. (120 mL) of product simulation solution (10:1 ratio of water to glycerin).
5. Cap bottle tightly to minimize evaporation.
6. Place bottle in bracket.
7. Replace probes, immersing at least 2" (50 mm).

## 12 Service

### 12.1 Refrigerant

**CAUTION**

- Review all safety instructions prior to recharging refrigerant. Refer to Section 1.1.
- Maintenance should only be performed by trained refrigeration technicians.

**Notes**

- Use only non-CFC R134A refrigerant.
- Refrigerators manufactured prior to 12 April 2012 may have an initial refrigerant charge greater than the charge listed in the table below.
- Pressure readings may vary based on chamber temperature and ambient air temperature.
- Normal low side pressures are 16 psi to 18 psi when unit is functioning at standard operating temperatures and measured at the end of the compressor cycle.
- If a refrigerant leak is suspected, Helmer recommends finding and fixing the leak prior to recharging the unit.

Full initial refrigerant charge varies by model and power requirements, which can be found on the product specification label.

**Table 12. Initial Charge by Model**

Model	Refrigerant	Power Requirements	Initial Charge
225	R134A	115 V, 60 Hz 230 V, 50 Hz 230 V, 60 Hz	10.1 oz. (286 g)
456	R134A	115 V, 60 Hz 230 V, 50 Hz 230 V, 60 Hz	12.5 oz. (354 g) 10.5 oz. (298 g)*

\* = units with light gray condensing coil



### 12.2 Replace LED Lamps

1. Switch AC ON/OFF switch OFF. Disconnect the battery.
2. Using a screwdriver, remove lamp strip from chamber wall.
3. Unsnap the defective LED and disconnect wires.
4. Snap new LED onto the lamp strip.
5. Connect the wires.
6. Using a screwdriver, attach lamp strip to chamber wall.
7. Switch AC ON/OFF switch ON. Reconnect the battery.
8. Press the MUTE button to disable the high temperature alarm while refrigerator reaches operating temperature.

### 12.3 Remove / Replace Unit Cooler Cover

The unit cooler cover must be removed when service to the control probe, fan motor(s) or coil is performed.

#### NOTICE

If unit cooler cover is not removed as detailed in this procedure the drain port may be damaged. Improper drainage may result in excessive icing and refrigerator's inability to maintain temperature.

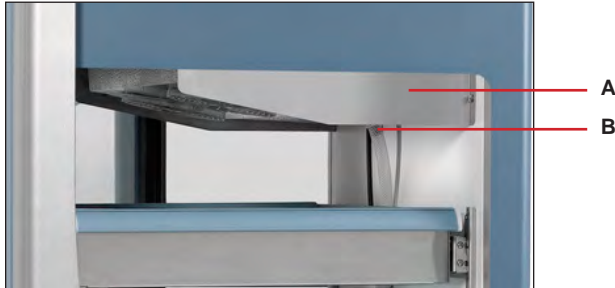

Label	Description
A	Unit cooler cover
B	Drain port

#### Remove Unit Cooler Cover

1. Switch AC ON/OFF switch OFF. Switch battery switch OFF.
2. Remove top drawer, basket, or shelf from the chamber.
3. Remove drain hose from unit cooler drain port by pulling drain hose downward while gently twisting to remove from drain port.
4. Push the slack in the drain hose aside.
5. Hold unit cooler cover in place to prevent dropping. Using a 5/16" socket wrench, remove four screws securing the unit cooler cover.
6. Carefully lower unit cooler cover to avoid damage to the fan wiring.

#### Install Unit Cooler Cover

1. Verify unit cooler wiring is connected and routed correctly.
2. Lift unit cooler cover into place. Front edge of the cover should be behind the unit cooler case.
3. Using a 5/16" socket wrench, install four screws to secure the unit cooler cover.
4. In the chamber, attach drain hose to unit cooler drain port.
5. Reinstall top drawer, basket, or shelf if previously removed.
6. Seal the opening around the drain hose on the back of the unit using putty.
7. Switch AC ON/OFF switch ON. Switch battery switch ON.
8. Touch **Mute** to disable the high temperature alarm while refrigerator reaches operating temperature.



### 13 Troubleshooting

**CAUTION**

Review all safety instructions prior to troubleshooting. Refer to Section 1.1.

#### 13.1 General Operation Problems

Problem	Possible Cause	Action
A drawer or basket does not slide easily.	Drawer or basket is misaligned or not level.	Confirm both slides for the drawer or basket are mounted at the same height.
	Drawer slides are not lubricated.	Using a lightweight oil, lubricate the bearings the slides.
	Debris in the drawer slides.	Pull the drawer or basket out and confirm the slides are free of debris. Clean the slides if necessary.
	Drawer slide is faulty.	Confirm the slide is operating correctly. Replace if necessary.
A door does not open easily.	Debris in the hinges.	Confirm the hinges are free of debris. Clean the hinges if necessary.
	Door hinges are not lubricated.	Using a general-purpose grease, lubricate the pivots in the hinges.
	Hinge cam is faulty.	Confirm the hinge cam is not damaged. Replace the cam if necessary.
The chamber temperature meets an alarm condition, but the appropriate temperature alarm is not active.	Temperature alarm setpoint was changed.	Check the current setpoints for the temperature alarms. Change the setpoints if necessary.
The chamber temperature displayed is higher or lower than the actual temperature.	Probe bottle is empty, or the amount of solution is too low.	Check the level of product simulation solution in the bottle. Refill the bottle if necessary.
	Monitor is not calibrated.	Confirm the monitor probe is reading correctly. Calibrate the monitor probe if necessary.
	Digital electronics are locked because of an interruption in power.	Reset the monitoring system.
	A component is faulty or internal connections are loose.	Contact Helmer Technical Service.
"Prob" appears on the display, but the chamber temperature is set correctly.	A component is faulty or internal connections are loose.	Contact Helmer Technical Service.

#### 13.2 Chamber Temperature Problems

Problem	Possible Cause	Action
"Prob" appears on the display, but the chamber temperature is set correctly.	Probe bottles are empty, or the amount of solution is too low.	Check the level of product simulation solution in the bottles. Refill the bottles if necessary. Refer to the refrigerator operation manual.
	Monitor probe(s) is not calibrated.	Check the chamber temperature calibration. Change calibration if necessary.
	Connections for the monitor probe are loose.	Check the probe connections. Secure the connections if necessary.
The chamber temperature does not stabilize at the refrigerator setpoint.	Probe bottle is empty.	Refill the probe bottle.
	Condenser grill is dirty.	Check the condenser grill. Clean the grill if necessary.
	Air circulation at the top of the chamber is not adequate.	Check if there are any items that may obstruct air flow and remove them if necessary.
	Ambient air temperature around the refrigerator is too high.	Confirm the refrigerator is placed appropriately.
	A component is faulty or internal connections are loose.	Contact Helmer Technical Service.
	Control probe is faulty.	Confirm the probe is providing resistance in the range of 98 Ω to 110 Ω. Replace the probe if necessary.
	Unit cooler fan is not running.	Check the voltage to the fan when door switch is activated. Replace the fan motor or door switch if necessary.
	Refrigerant level is too low.	Check the refrigeration lines for leaks and repair them if necessary. Check the refrigerant level. Recharge the refrigerant if necessary.

Problem	Possible Cause	Action
The compressor runs continuously.	Refrigerator setpoint is set too low.	Confirm the setpoint is set within the operating range. Change if necessary.
	Control probe is out of calibration.	Confirm the probe is providing accurate temperature readings.
	Control probe is faulty.	Confirm the probe is providing resistance in the range of 98 Ω to 110 Ω. Replace the probe if necessary.
	Solid state relay is defective.	Confirm solid state relay is not being commanded on. Replace if necessary.
		Check CP board operation.
Temperature controller board is faulty.	Replace parts with those included in the control board kit, or replace the monitor/control board.	

### 13.3 Alarm Activation Problems

Problem	Possible Cause	Action
The refrigerator is in an alarm condition, but the appropriate alarm is not audible or active.	Alarm buzzer is faulty.	Replace the alarm buzzer.
	Audible alarms have been muted.	Verify the Alarm Disable key switch is not turned Off.
	A component is faulty or internal connections are loose.	Contact Helmer Technical Service.
The High Temperature alarm activates when the door is opened, then clears shortly after the door is closed.	Probe bottle is empty.	Check level of product simulation solution in the bottle. Refill bottle if necessary.
	High temperature alarm setpoint is set too low.	Check the setpoint. Change the setpoint if necessary.
	Unit cooler fan continues to run while the door is open.	Test the door switch and unit cooler fan connections. Secure the connections if necessary. Replace the door switch or fan motor if necessary.
	Connections for the monitor probe are loose.	Check the probe connections. Secure the connections if necessary.
	Monitor probe is faulty.	Test the probe. Replace the probe if necessary.
	A component is faulty or internal connections are loose.	Contact Helmer Technical Service.
The refrigerator is connected to power, but the AC Power Failure alarm is active.	Outlet connection is faulty.	Verify power at the outlet. Repair the original outlet or connect to a different outlet if necessary.
	Power cord is faulty.	Confirm power cord is connected securely. Secure power cord if necessary.
	Temperature control transformer is faulty.	Replace power supply board or temperature control transformer.
	A component is faulty or internal connections are loose.	Contact Helmer Technical Service.
	Circuit breaker was tripped (230 V models).	Confirm circuit breaker is seated. Push circuit breaker to reset if necessary.
The Door Open alarm is activating sporadically.	Door(s) are not closing completely.	Confirm the hinge cams are not damaged. Replace the cams if necessary.
	One or more door switches are faulty.	Replace the door switch or switches.
	Temperature monitor/controller board is faulty.	Confirm the temperature monitor/controller board is operating correctly. Replace the board if necessary.

### 13.4 Condensation Problems

Problem	Possible Cause	Action
There is excessive water in the water evaporation tray.	Humid air is entering the chamber.	Confirm the refrigerator is level, and the doors are aligned, closing tightly, and sealing correctly. Correct issues as necessary.
	Heater in the evaporation tray is faulty.	Confirm the heater is hot and is drawing the appropriate current. (115 V unit - 0.43 A to 0.55 A current draw; 230 V unit - 0.21 A to 0.35 A current draw)
There is excessive water in the chamber.	Humid air is entering the chamber.	Confirm the refrigerator is level, and the doors are aligned, closing tightly, and sealing correctly. Correct issues as necessary.
	Connection between the unit cooler and the drain tube is loose.	Confirm the connection is secure. Tighten the connection if necessary.
	Drain line is plugged.	Confirm the drain tube is free of debris. Remove debris if necessary.
There is excessive humidity on the doors.	Humid air is entering the chamber.	Confirm the refrigerator is level, and the doors are aligned, closing tightly, and sealing correctly. Correct issues as necessary.
	Relative humidity around the refrigerator is too high.	Confirm the refrigerator is placed properly. Refer to the refrigerator operation manual.
Water leaks from the bottom of the refrigerator.	Humid air is entering the chamber.	Confirm the refrigerator is level, and the door is aligned, closing tightly, and sealing correctly.
	Excessive water is found in the evaporation tray inside the refrigerator.	Contact Helmer Technical Service to correct issues as necessary.

## 14 Horizon Series™ Parts

### Notes

- Before replacing parts, protect items in refrigerator from extended exposure to adverse temperature.
- Allow refrigerator temperature to stabilize at setpoint after replacing parts or after extended door opening.
- Circuit boards are sensitive to static electricity and can be damaged by electrostatic discharge. Use proper ESD precautions when handling these boards.
- The condensate evaporator is located below the cabinet and is accessed by removing the evaporator cover on the control side of the refrigerator.

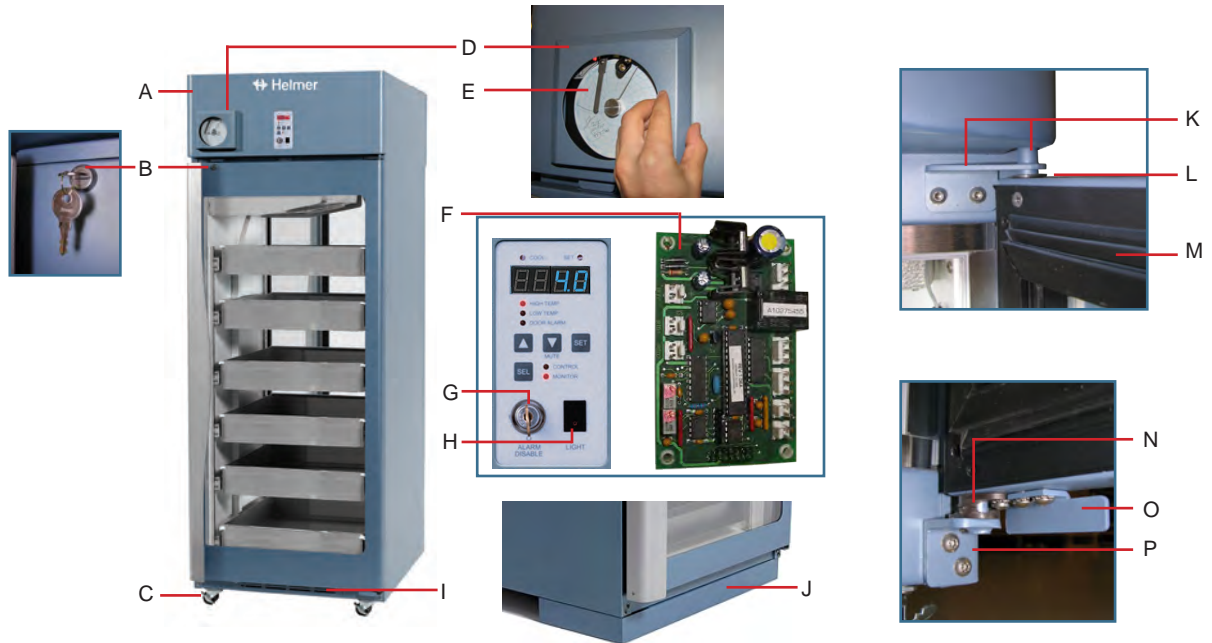

Letter	Description	Part Number	Volts	Letter	Description	Part Number	
A	Bezel (* = without chart recorder door)	800072-1	-	I	Condensate evaporator kit	800004-1	115
		800071-1*	-			800212-1	230
B	Door lock	220540	-	J	Skirt * = 2 door models; ** = 4 door models	400862-1*	-
C	Caster	220467	-			400862-2**	-
D	Temperature chart recorder	800025-1	115	K	Upper hinge * = Left hinge; ** = Right hinge	400376-2*	-
		800025-2	230			400376-1**	-
E	Chart paper (52 sheets)	220366	-	L	Hinge bearings	220375	-
Not Shown	Chart recorder back-up battery	120218	-	M	Door gasket	320726-1	-
F	Control board assembly * = serial numbers 2015494 and greater	800006-1	-	N	Lower hinge cam (quantity 2)	320742-1	-
		800276-1*	-	O	Door stop	320763-1	-
G	Alarm key switch	120227	-	P	Lower hinge bracket * = Right hinge; ** = Left hinge	400377-1*	-
H	Light switch	120202	-			400377-2**	-

**CAUTION**

Disconnect refrigerator from power when removing and replacing LED lamps

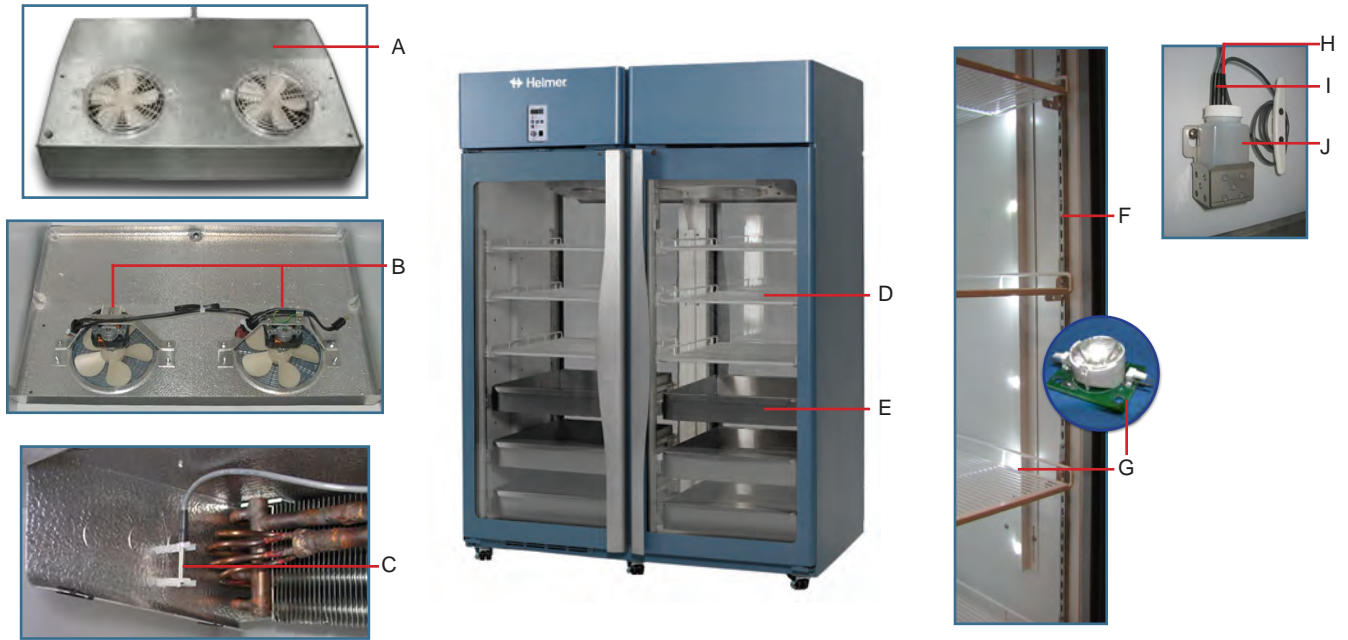

Letter	Description	Model	Part Number	Volts	Letter	Description	Part Number
A	Unit cooler assembly	225	800831-1	115	Not Shown	Two-way roll-out basket assembly (Includes drawer with attached slides and hardware)	400858-1
		456	800833-1	115			Bridge shelf * = 18" depth; ** = 24" depth
		225	800831-2	230		400845-2**	
		456	800833-2	230			
B	Unit cooler fan motor	-	800836-1	115	F	Shelf standard	320733-1
		-	800835-1	230	G	LED lamp	800049-1
C	Control probe	-	800028-1	-	H	Chart recorder probe	800024-1
D	Shelf	-	400857-1	-	I	Primary monitor probe	800038-1
E	Two-way drawer assembly (Includes drawer with attached slides and hardware)	-	400856-2	-	J	Probe bottle and glycerin kit	400922-1
					Not Shown	Door switch	120380

Horizon Series Information

**CAUTION**

- Disconnect the refrigerator from AC power before opening the electrical box.

**Note**

Circuit boards are sensitive to static electricity and can be damaged by electrostatic discharge. Use proper ESD precautions when handling these boards.

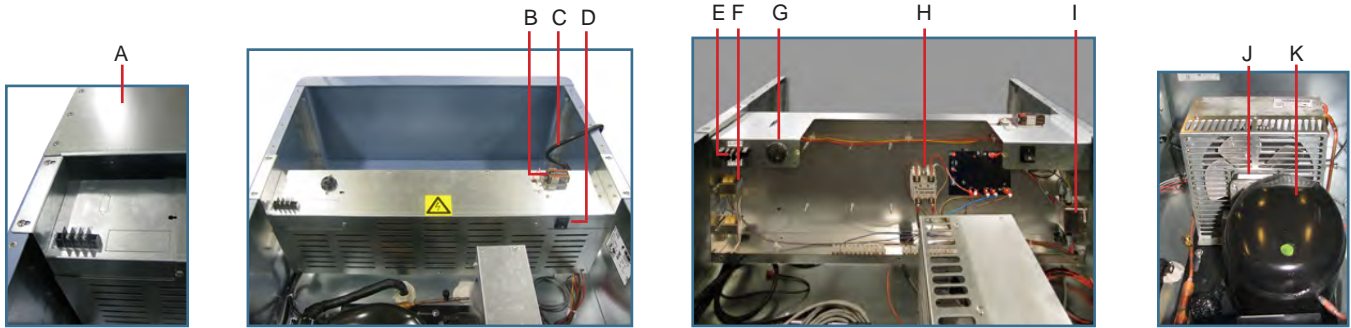

Letter	Description	Part Number	Volts	Letter	Description	Model	Part Number	Volts	Hz
A	Cover for clean room side	-	-	J	Condenser fan motor	225	120467	115	-
B	Monitoring system back-up battery	120399	-			456	120469	115	-
C	Power cable	120630	-			225	120471	230	-
D	Main power switch	120478	-			456	120473	230	-
E	Remote alarm contacts	-	-	K	Compressor	225	400888-1	115	-
F	Temperature control transformer	800086-1	115			456	400888-2	115	-
		800086-2	230			225	800210-1	230	50
G	Alarm buzzer	120160	-			456	800211-1	230	50
H	Solid state relay	120426	-			225	800208-1	230	60
I	Power line filter	120400	-	456	800209-1	230	60		
				Not Shown	12 V cabinet lighting power supply	-	120505	-	-

# 15 Schematics

## 15.1 HB and HPR Models

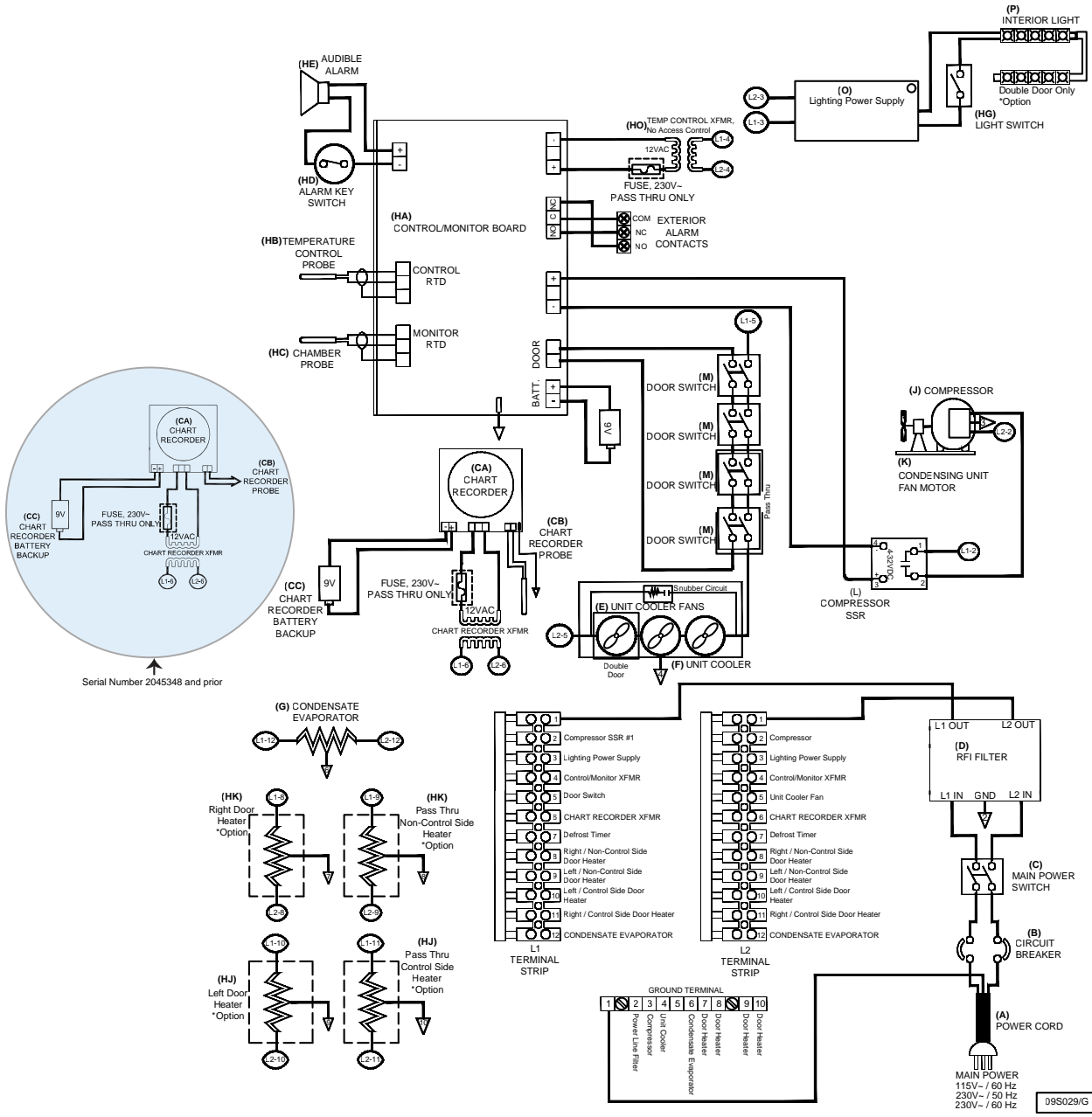

THESE DRAWINGS AND SPECIFICATIONS ARE THE SOLE PROPERTY OF HELMER INC. AND SHALL NOT BE REPRODUCED OR USED AS THE BASIS FOR MANUFACTURE OR SALES OF APPARATUS WITHOUT THE APPROVAL OF HELMER INC.

Horizon Series Information

### 15.3 Defrost Timer for HPR Model; 225 and 456 Configuration

**Note**

The Defrost Timer applies only to HPR models with serial number 2044368 and prior. Some exceptions may apply. Contact Helmer Technical Service at techservice@helmerinc.com for details.

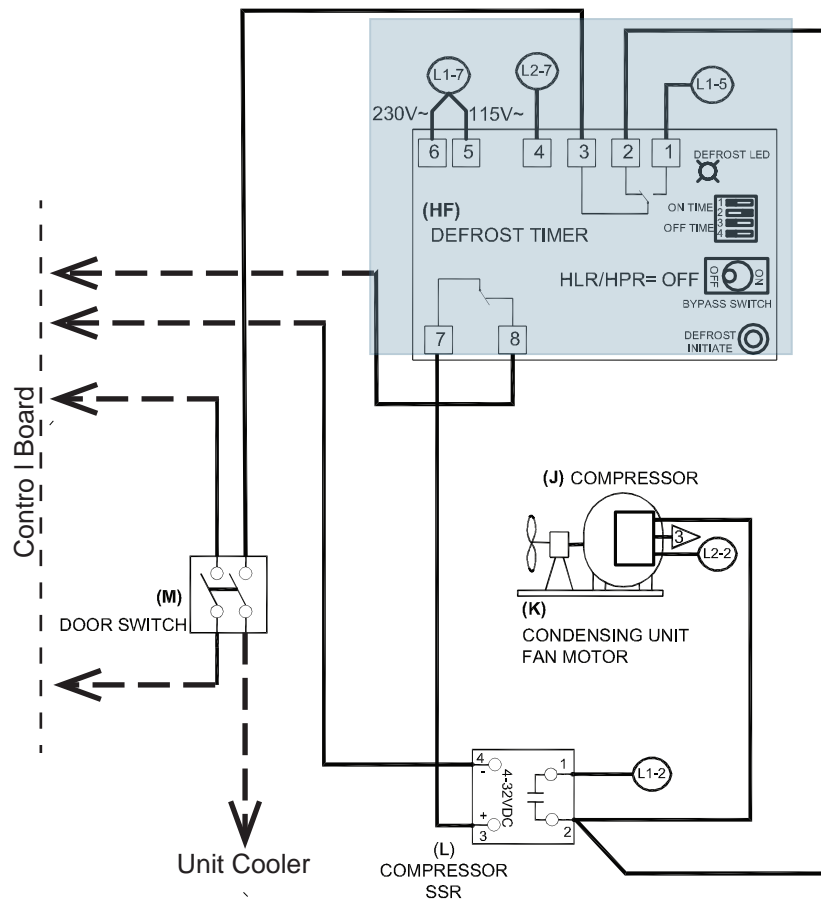

THESE DRAWINGS AND SPECIFICATIONS ARE THE SOLE PROPERTY OF HELMER INC. AND SHALL NOT BE REPRODUCED OR USED AS THE BASIS FOR MANUFACTURE OR SALES OF APPARATUS WITHOUT THE APPROVAL OF HELMER INC.



## 16 Compliance

### 16.1 Safety Compliance



This device complies with the requirements of directive 93/42/EEC concerning Medical Devices, as amended by 2007/47/EC.

This product is certified to applicable UL and CSA standards by a NRTL.



This device complies with FCC Radiated and Conducted Emissions Approval to CFR47, Part 15; Class A levels

### 16.2 Environmental Compliance



This device complies with the 2011/65/EU Directive for the Restriction of Hazardous Substances (RoHS).



This device falls under the scope of Directive 2102/19/EU Waste Electrical and Electronic Equipment (WEEE) .

When disposing of this product in countries affected by this directive:

- ◆ Do not dispose of this product as unsorted municipal waste.
- ◆ Collect this product separately.
- ◆ Use the collection and return systems available locally.

For more information on the return, recovery, or recycling of this product, contact your local distributor.

### 16.3 EMC Compliance

Helmer Scientific Refrigerators meet the applicable requirements of IEC61326 and EN55011 and are intended for use in the electromagnetic environment specified in 8.1 Operating Standards. The customer or the user of these devices should assure they are used in such environment.



Helmer Scientific  
14400 Bergen Blvd.  
Noblesville, Indiana 46060 USA



Emergo Europe  
Prinsessegracht 20  
2514 AP The Hague  
The Netherlands

## Appendix A: Warranty

### Rel.i™ Product Warranty USA and Canada

For technical service needs, please contact Helmer at 800-743-5637 or [www.helmerinc.com](http://www.helmerinc.com). Have the model and serial number available when calling.

#### Rapid Resolution

When a warranty issue arises it is our desire to respond quickly and appropriately. The service department at Helmer is there for you. Helmer will oversee the handling of your warranty service from start to finish. Therefore, Helmer must give advance authorization for all service calls and/or parts needs relating to a warranty issue. Any repeat service calls must also be authorized as well. This allows for proper diagnosis and action. Helmer will not be responsible for charges incurred for service calls made by third parties prior to authorization from Helmer. Helmer retains the right to replace any product in lieu of servicing it in the field.

#### Compressor

For the warranty period listed below, Helmer will supply the refrigeration compressor, if it is determined to be defective, at no charge, including freight. Helmer will not be liable for installation, refrigerant, or miscellaneous charges required to install the compressor beyond the first year of the warranty period.

- ◆ i.Series model compressor warranty period is seven (7) years.
- ◆ Horizon Series model compressor warranty period is five (5) years.

#### Parts

For a period of two (2) years, Helmer will supply at no charge, including freight, any part that fails due to defects in material or workmanship under normal use, with the exception of expendable items. Expendable items such as glass, filters, light bulbs, and door gaskets are excluded from this warranty coverage. Inspection of defective parts by Helmer will be final in determining warranty status. Warranty procedures must be followed in all events.

#### Labor

For a period of one (1) year, Helmer will cover repair labor costs (including travel) and the cost of refrigerant and supplies necessary to perform authorized repairs. Repair service must be performed by an authorized Helmer service agency following the authorization process detailed above. Alternatively, your facility's staff may work with a Helmer technician to make repairs. Labor costs for repairs made by unauthorized service personnel, or without the assistance of a Helmer technician, will be the responsibility of the end user.

#### Additional Warranty Information

The time periods set forth above begin two (2) weeks after the original date of shipment from Helmer. Warranty procedures set forth above must be followed in all events.

THERE ARE NO WARRANTIES WHICH EXTEND BEYOND THE DESCRIPTION ON THE FACE HEREOF. THIS WARRANTY IS EXCLUSIVE AND IN LIEU OF ALL OTHER WARRANTIES, EXPRESS OR IMPLIED, INCLUDING WITHOUT LIMITATION ANY WARRANTY OF MERCHANTABILITY OR FITNESS FOR A PARTICULAR PURPOSE. NO WARRANTIES OF MERCHANTABILITY OR FITNESS FOR PARTICULAR PURPOSE SHALL APPLY.

THE LIABILITY, IF ANY, OF HELMER FOR DIRECT DAMAGES WHETHER ARISING FROM A BREACH OF ANY SALES AGREEMENT, BREACH OF WARRANTY, NEGLIGENCE, OR INDEMNITY, STRICT LIABILITY OR OTHER TORT, OR OTHERWISE WITH RESPECT TO THE GOODS OR ANY SERVICES IS LIMITED TO AN AMOUNT NOT TO EXCEED THE PRICE OF THE PARTICULAR GOODS OR SERVICES GIVING RISE TO THE LIABILITY. IN NO EVENT SHALL HELMER BE LIABLE FOR ANY INDIRECT, INCIDENTAL, CONSEQUENTIAL, OR SPECIAL DAMAGES, INCLUDING WITHOUT LIMITATION DAMAGES RELATED TO LOST REVENUES OR PROFITS, OR LOSS OF PRODUCTS.

This warranty does not cover damages caused in transit, during installation by accident, misuse, fire, flood, or acts of God. Further, this warranty will not be valid if Helmer determines that the failure was caused by a lack of performing recommended equipment maintenance (per Helmer manual) or by using the product in a manner other than for its intended use. Installation and calibration are not covered under this warranty agreement.

#### Outside of USA and Canada

Consult your local distributor for warranty information.

END OF MANUAL

